

KINWA  
金和車床

[www.kinwa-lathe.com](http://www.kinwa-lathe.com)

# FLAT BED CNC LATHE

## 平台式CNC車床

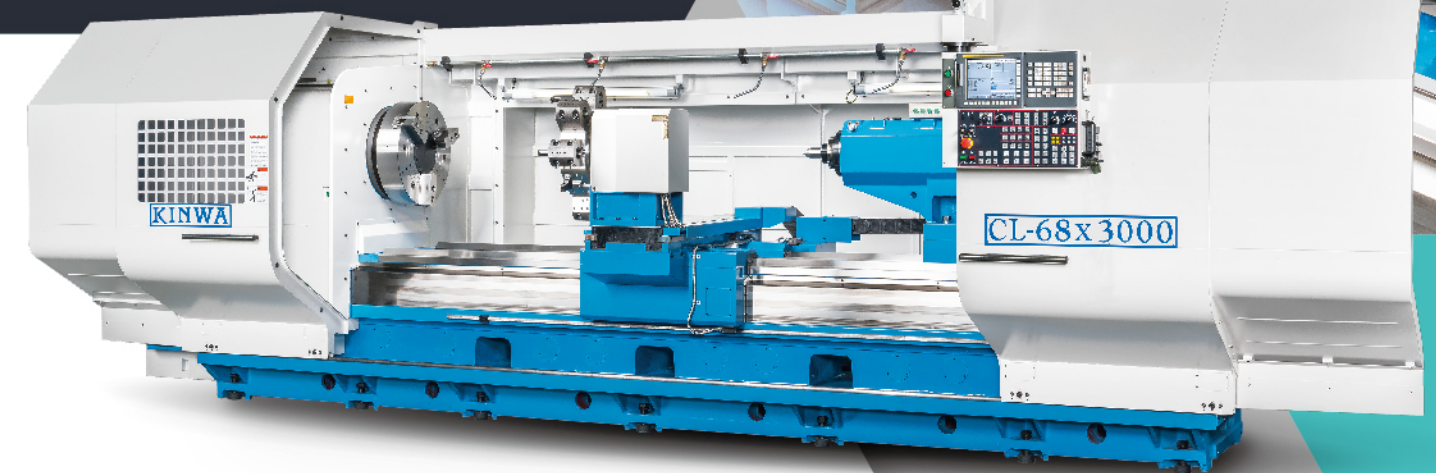

KINWA  
金和車床

金和精密股份有限公司  
CHIN HUNG MACHINERY CO., LTD.

台中市大雅區田心街10號  
No.10, Tianxin St., Daya Dist.,  
Taichung City 428, Taiwan  
Tel: +886-4-25663114 · 25666113  
Fax: +886-4-25665254  
E-mail: [ufkinwa@ms15.hinet.net](mailto:ufkinwa@ms15.hinet.net)  
[www.kinwa-lathe.com](http://www.kinwa-lathe.com)



**CL-68 / CL-78 series**

精度準確 品質卓越

SUPREME ACCURACY. EXCELLENT QUALITY.



最佳化結構設計，展現獨特重切削能力，以及優異抗震特色。

**WITH THE OPTIMAL STRUCTURAL DESIGN,  
KINWA FLAT BED CNC LATHE EXHIBITS  
EXTRAORDINARY HEAVY CUTTING CAPACITY AND  
OUTSTANDING DAMPENING CHARACTERISTICS.**



**懸吊式操作箱 (適用CL-68機型)**

懸吊式操作箱可以移動到最佳操作位置，並且可以作角度旋轉，使操作更方便。

**PENDANT TYPE OPERATION BOX  
(FOR CL-68 SERIES)**

The pendant type operation box can be moved to an appropriate operation position and swiveled.

## FLAT BED CNC LATHE 平台式CNC車床

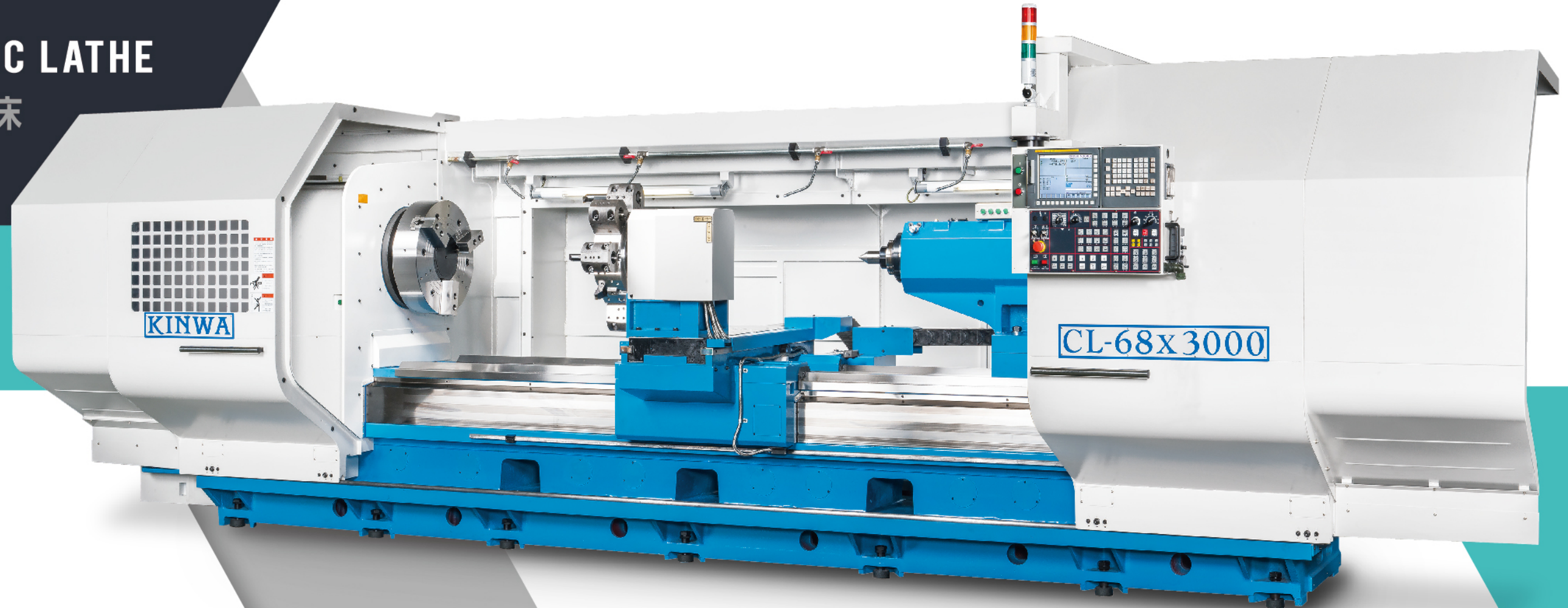

- 旋徑: 1150, 1500 mm
- 兩心間距: 1000~7000 mm
- 主軸孔徑: Ø181, Ø 255, Ø 375, Ø 530 mm (僅適用於CL-78機型)
- 主軸馬達: 60 HP
  
- Swing: 1150, 1500 mm
- Dist. between centers: 1000~7000 mm
- Spindle bore: Ø181, Ø 255, Ø 375, Ø 530 mm (only for CL-78)
- Spindle motor 60 HP

- 平台式機體結構，具有最佳的結構剛性，無機體變形之慮。
- 床身與底座為一體式結構設計，有效增加整體結構剛性。
- 橫向滑座為方形硬軌，確保重切削時之穩定性。
- 尾座可安裝夾頭，兼具副主軸功能。
- 60 HP強力主軸馬達。
- 最大主軸孔徑可達Ø530 mm。
- V8油壓刀塔，自動換刀快速。

- The flat bed machine structure features optimal structural rigidity without structural-deformation problem.
- The bed and base are one-piece constructed that effectively boosts the rigidity of the entire structure.
- Square slideways for the cross slide ensures high stability in heavy cutting.
- The tailstock can mount with a chuck to achieve a sub-spindle function.
- Extra powerful 60 HP spindle motor.
- Max. spindle bore is of up to Ø530 mm.
- V8 hydraulic turret provides fast automatic tool change.





### 主軸箱

- 高剛性主軸箱結構。在重切削時，更凸顯其非凡的穩定性。
- 主軸箱內部齒輪採用高精度之日本JIS一級齒輪，運轉順暢、低噪音。
- 主軸箱潤滑為泵浦強制潤滑系統。

### HEADSTOCK

- The headstock is a highly rigid structure, which offers stability in heavy cutting.
- All gears in the headstock employ high precision Japan JIS class 1 gears, assuring smooth and low-noise operation.
- Headstock lubrication is a forced lubrication system operated by a pump.



### 主軸

- 主軸孔徑: Ø181 mm。
- 多種大孔徑主軸供選擇: Ø255, Ø375, Ø530 mm。
- 主軸採用高精密斜度滾柱軸承。重切削時，穩定性優異。

### SPINDLE

- Spindle bore: Ø181 mm.
- Various extra large spindle bores to select: Ø255, Ø375, Ø530 mm.
- The spindle associate with high precision taper roller bearing that offers outstanding stability in heavy cutting.

### V8油壓刀塔

- 立式V8油壓刀塔為標準配備。
- 選刀方式為雙向，任意刀號選刀。
- 最大刀具尺寸: 外徑刀 □32 mm。內徑刀 Ø60 mm。

### V8 HYDRAULIC TURRET

- V8 hydraulic turret is a standard accessory.
- Tool selection method is bi-directional, random tool selection.
- Max. tool size: O.D. tool □32 mm, I.D. tool Ø60 mm.

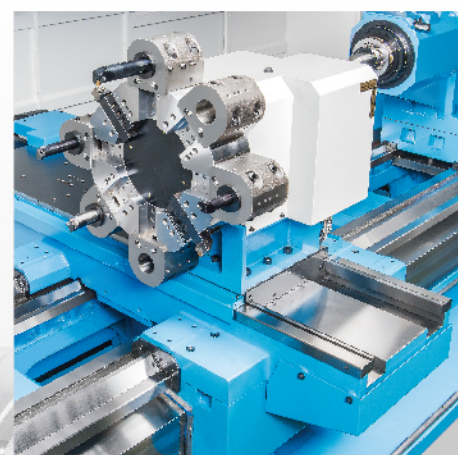

### 橫向滑座方軌

橫向滑座之滑道採用方形硬軌設計，力流線分佈更佳，耐重切削能力提升。

### 鞍座及橫向滑座

X, Z軸採用個別伺服馬達驅動，並經由精密滾珠螺桿傳動。進給順暢、定位精準。

### SQUARE WAYS FOR CROSS SLIDE

The cross slide moves on square slideways featuring better distribution of force flow lines, thus boosting heavy cutting capacity.

### CARRIAGE AND CROSS SLIDE

X, Z- axis are driven by individual servo motor and transmitted through high precision ball screws, that provide extremely smooth feed and high positioning accuracy.

### 副主軸式尾座

- 移動，採用獨立馬達驅動，方便快速。
- 可安裝夾頭。
- 尾座心軸可使用MT#6之固定頂心。
- Ø240 mm超大心軸直徑，提供大工件之穩固支撐。

### TAILSTOCK WITH SUB-SPINDLE FUNCTION

- The entire tailstock movement and the quill movement are operated by independent motor for added convenience.
- It suitable to mount with a chuck.
- MT#6 dead center for the tailstock quill.
- A large diameter Ø240 mm quill can hold a large workpiece firmly.

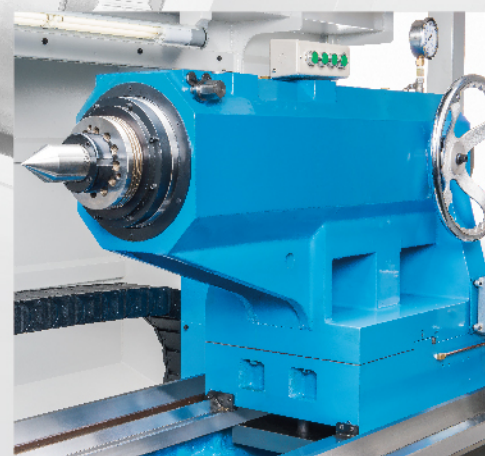

(標配 STANDARD)

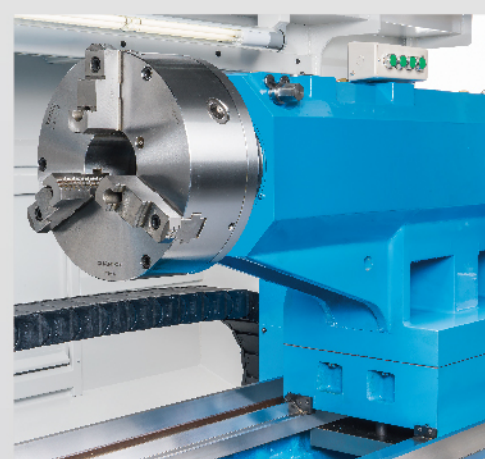

(選配 OPTIONAL)

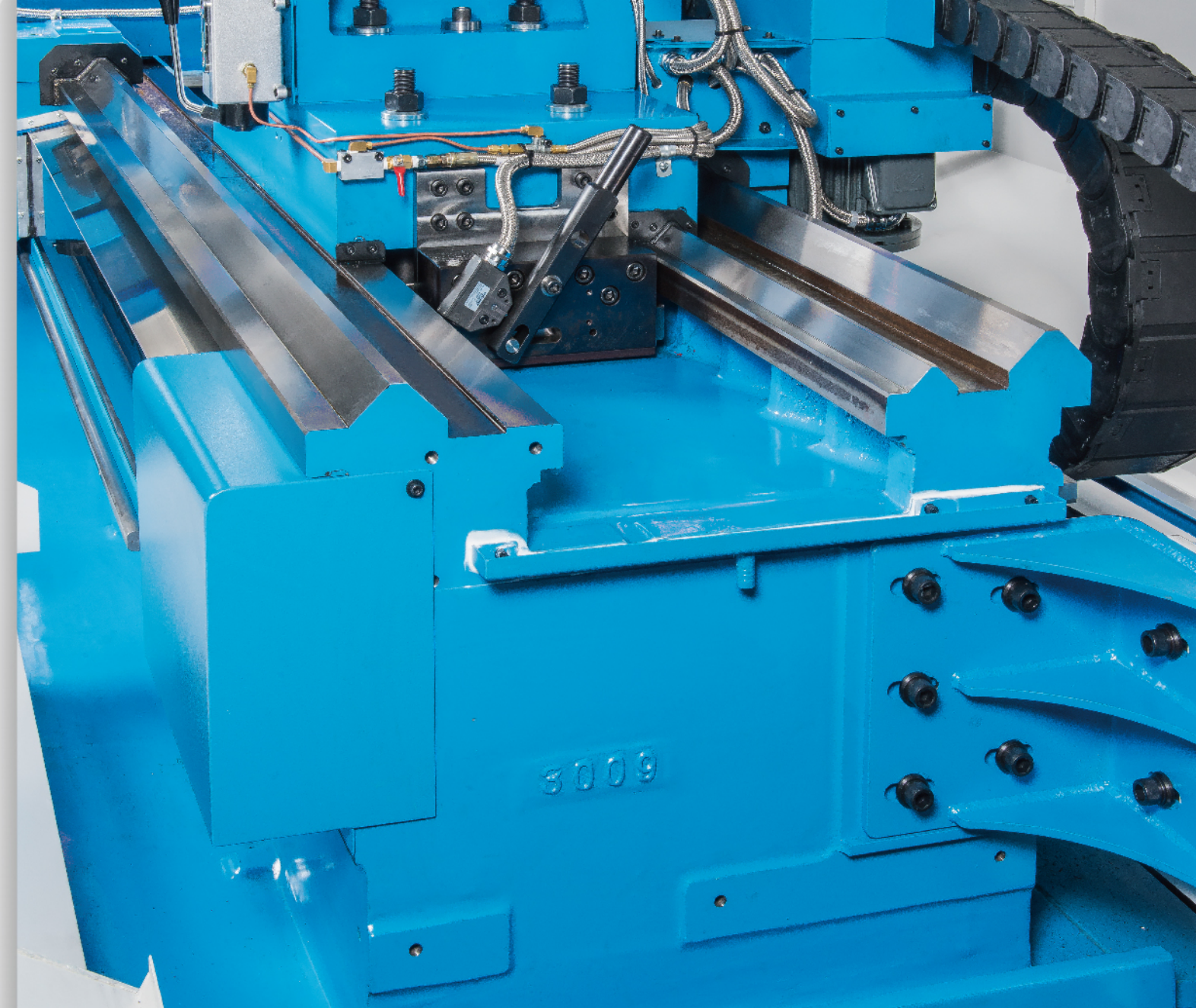

## 一體式床身與底座

## ONE-PIECE CONSTRUCTED BED AND BASE

- 床身與底座為一體式結構設計，有助於提升結構剛性。
- 床身與底座採用高級鑄鐵製成，並經應力消除，多年使用後，床身仍無變形之慮。
- 床身滑道經熱處理硬化(硬度高達HS70)，再經精密研磨，具有優異的耐磨耗性。
- 床身具有三個“V”型滑道及一個“平面”型滑道，以確保加工之精度。
- 鞍座滑道為二個“V”型滑道，直線精度高。
- The bedway and base are designed with a one-piece structure to help upgrade structural rigidity.
- The bedway and base are manufactured from high quality casting, and stress relieved for deformation – free performance year after year.
- Bed slideways are hardened (hardness HS70) and precision ground, featuring outstanding wear-resistance.
- The bedway is designed with three “V” and one “flat” slideways to ensure machining accuracy.
- The saddle moves on double “V” slideways to achieve high straightness accuracy.



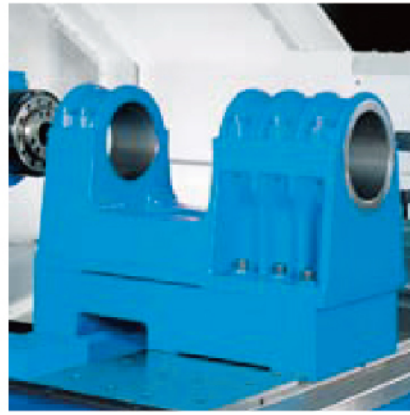

### 搪孔刀座 (不含刀桿) (選配)

- 搪孔刀座安裝在橫向滑座上。
- 可依客戶要求提供刀桿及各種尺寸之襯套。

### BORING ATTACHMENT (WITHOUT BORING BAR) (OPTIONAL)

- The boring attachment is installed on the cross slide.
- Upon customer request, boring bar and various sizes of sleeves can be supplied.

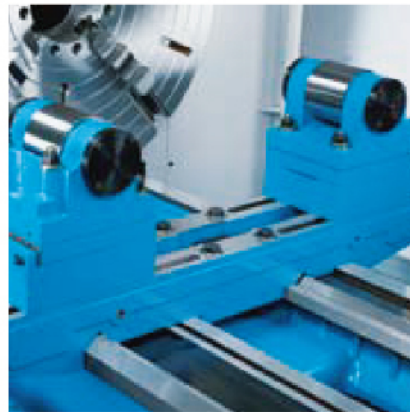

### 滾輪架 (選配)

- 滾輪架安裝在床身上。
- 穩重的滾輪架結構，適用於支撐超大直徑之工件。

### ROLLER BRACKET (OPTIONAL)

- The roller bracket is installed on the bed.
- With its massive construction, the roller bracket provides a stable support for extra large diameter workpiece.



### 後夾頭 (選配)

本機可依客戶要求在主軸尾端加裝一個夾頭，形成前、後夾頭夾持工件。特別適用於長工件之夾持，有效提升加工之穩定性。

### REAR CHUCK (OPTIONAL)

The machine is available to mount with an additional chuck at the rear end of the spindle, allows the workpiece to be clamped by the front and rear chucks. This chucking system increased stability when machining a long workpiece especially .

## 主軸轉速 / 馬達輸出曲線圖 SPINDLE SPEED / OUTPUT DIAGRAM

### (FANUC α40i)

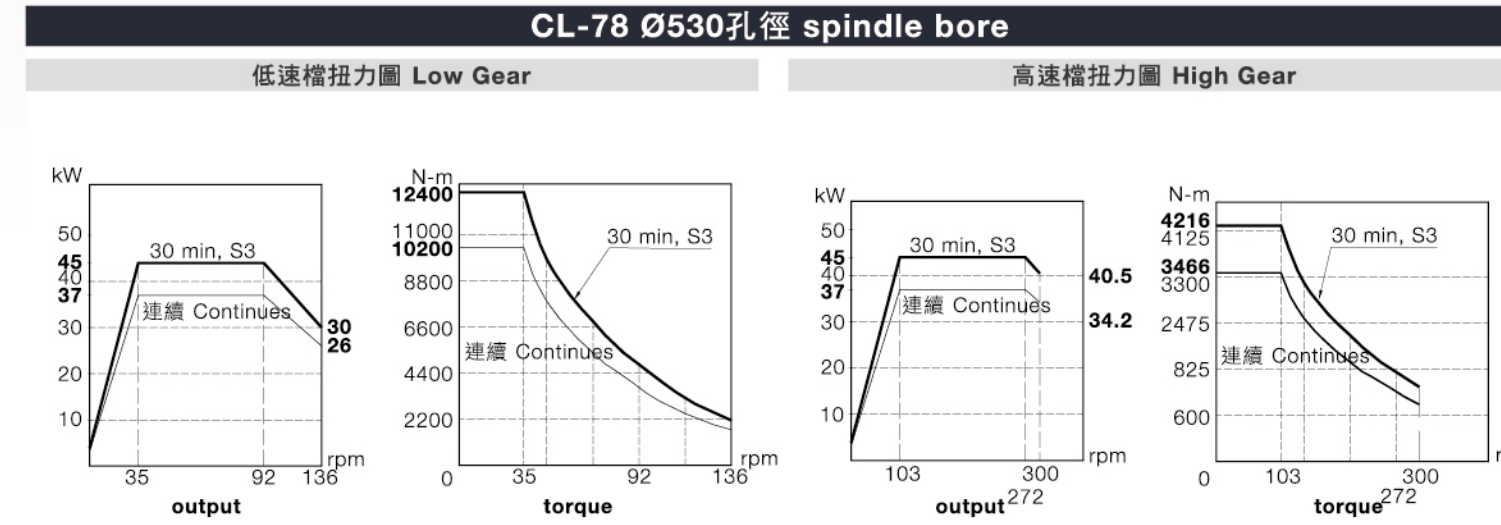
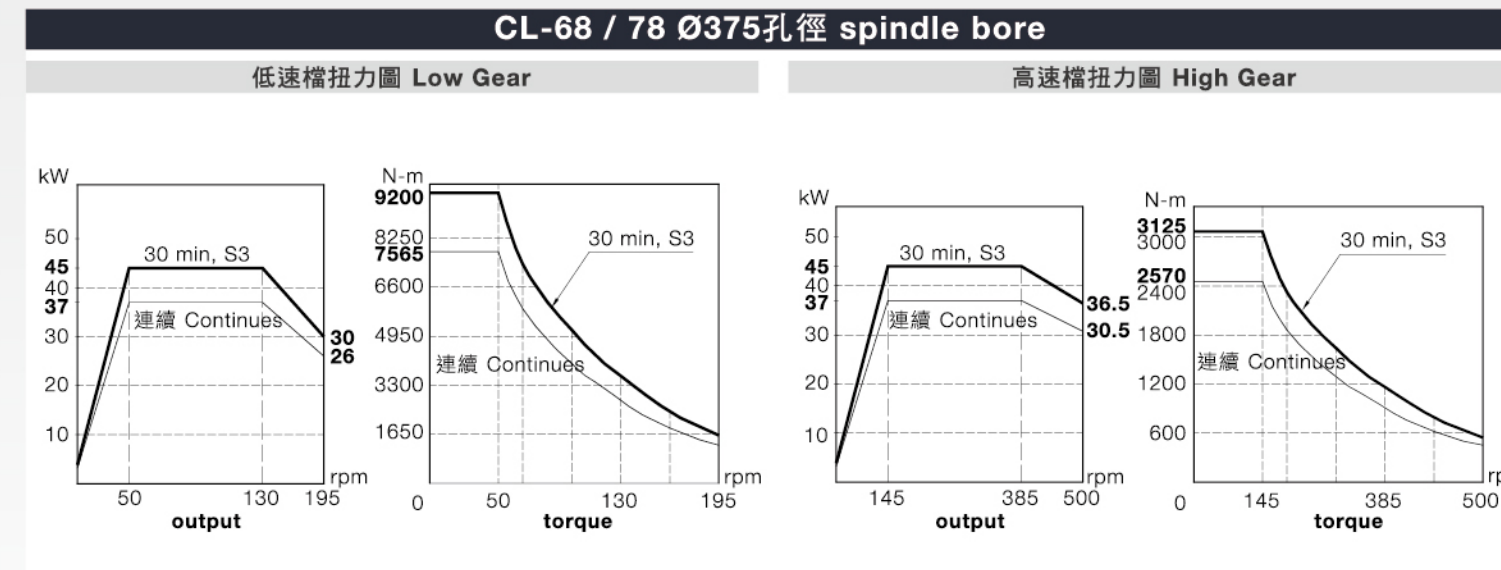
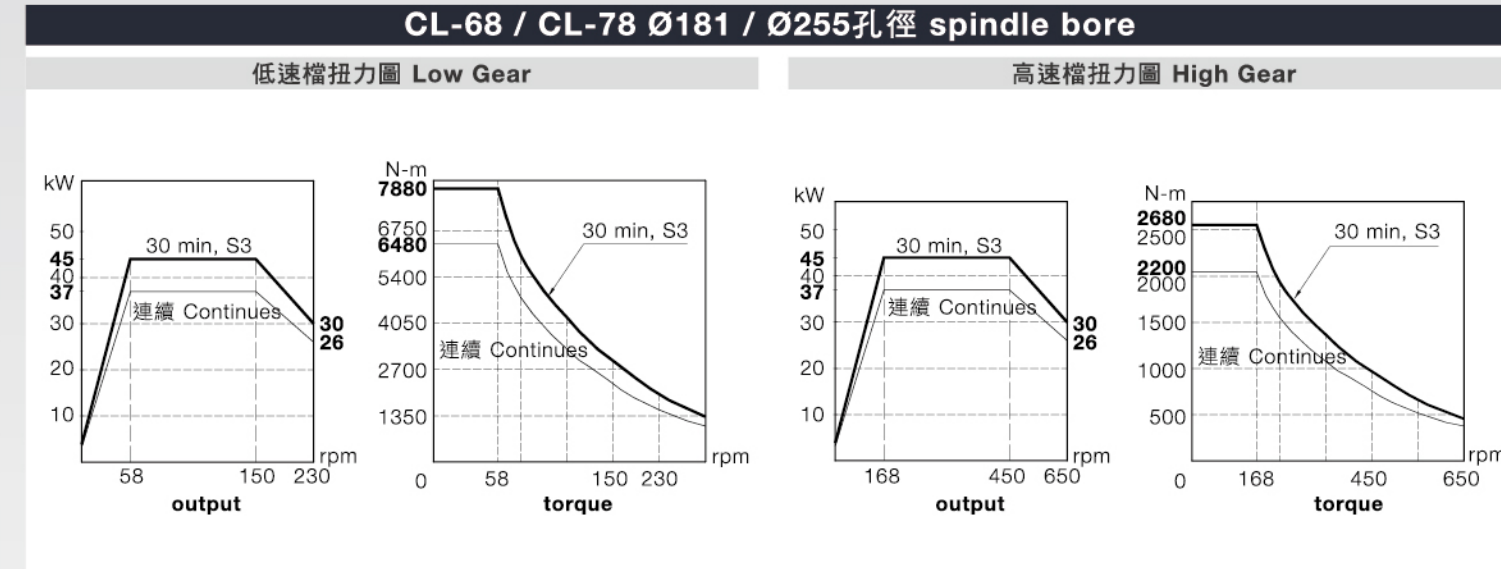

## 工作行程圖 WORKING TRAVEL DIAGRAM

### CL-68 V8

機型 Model	B行程 Travel			
	Ø181 / Ø255孔徑 spindle bore	Ø375孔徑 spindle bore	Ø181 / Ø255孔徑 spindle bore	Ø375孔徑 spindle bore
CL-68X1000	1020	950	950	900
CL-68X2000	2020	1950	1950	1900
CL-68X3000	3020	2950	2950	2900
CL-68X4000	4020	3950	3950	3900
CL-68X5000	5020	4950	4950	4900
CL-68X6000	6020	5950	5950	5900
CL-68X7000	7020	6950	6950	6900

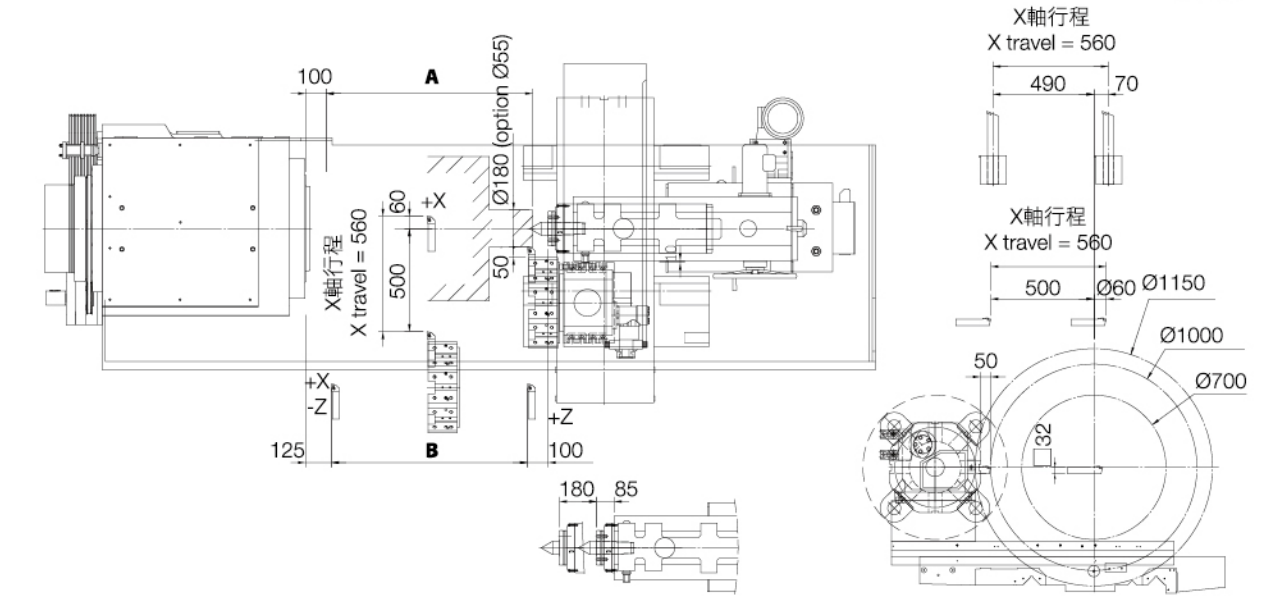
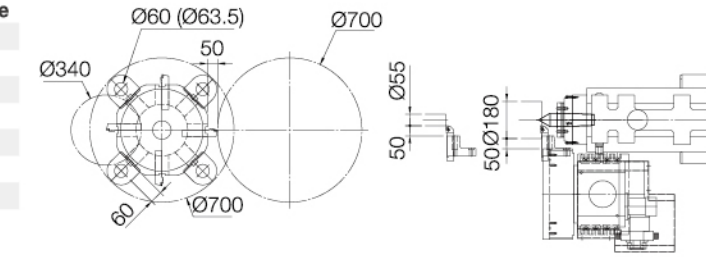

### CL-78 V8

機型 Model	B行程 Travel			
	Ø181 / Ø255孔徑 spindle bore	Ø375孔徑 spindle bore	Ø181 / Ø255孔徑 spindle bore	Ø375孔徑 spindle bore
CL-78X2000	2075	2025	1975	1900
CL-78X3000	3075	3025	2975	2900
CL-78X4000	4075	4025	3975	3900
CL-78X5000	5075	5025	4975	4900
CL-78X6000	6075	6025	5975	5900

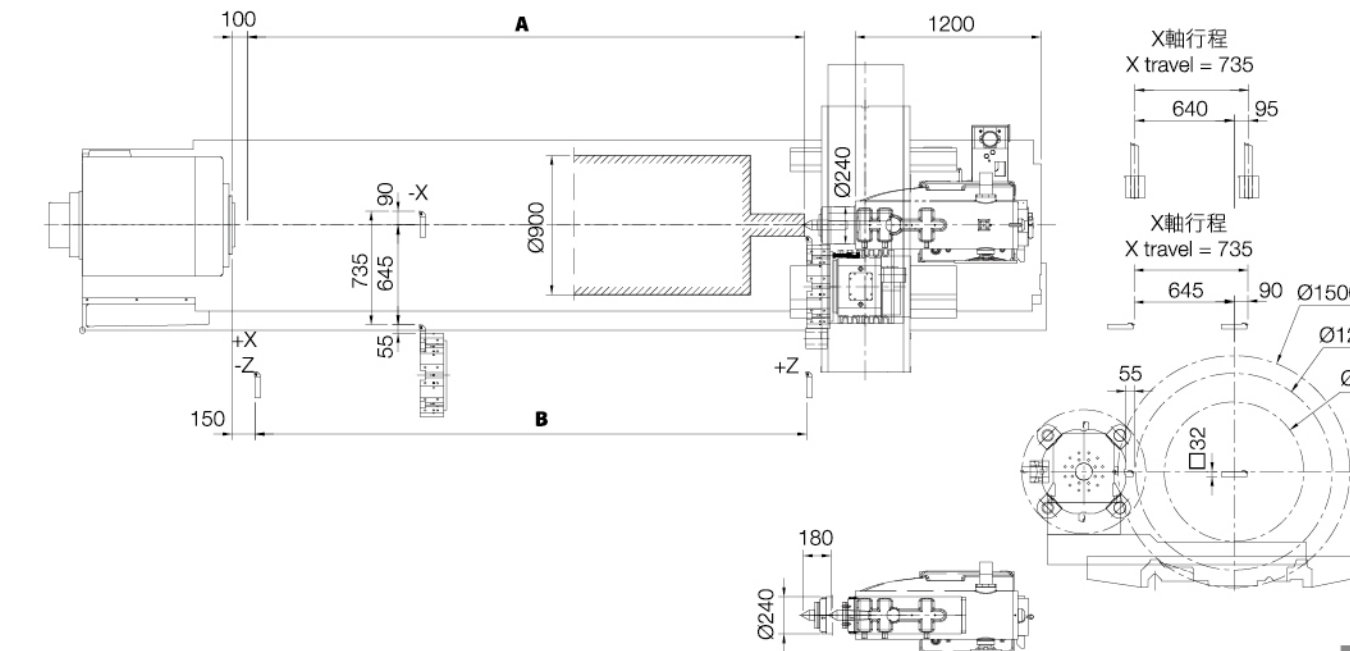
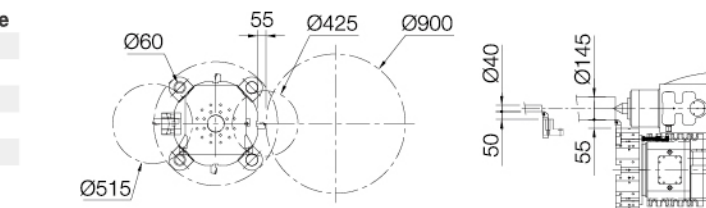



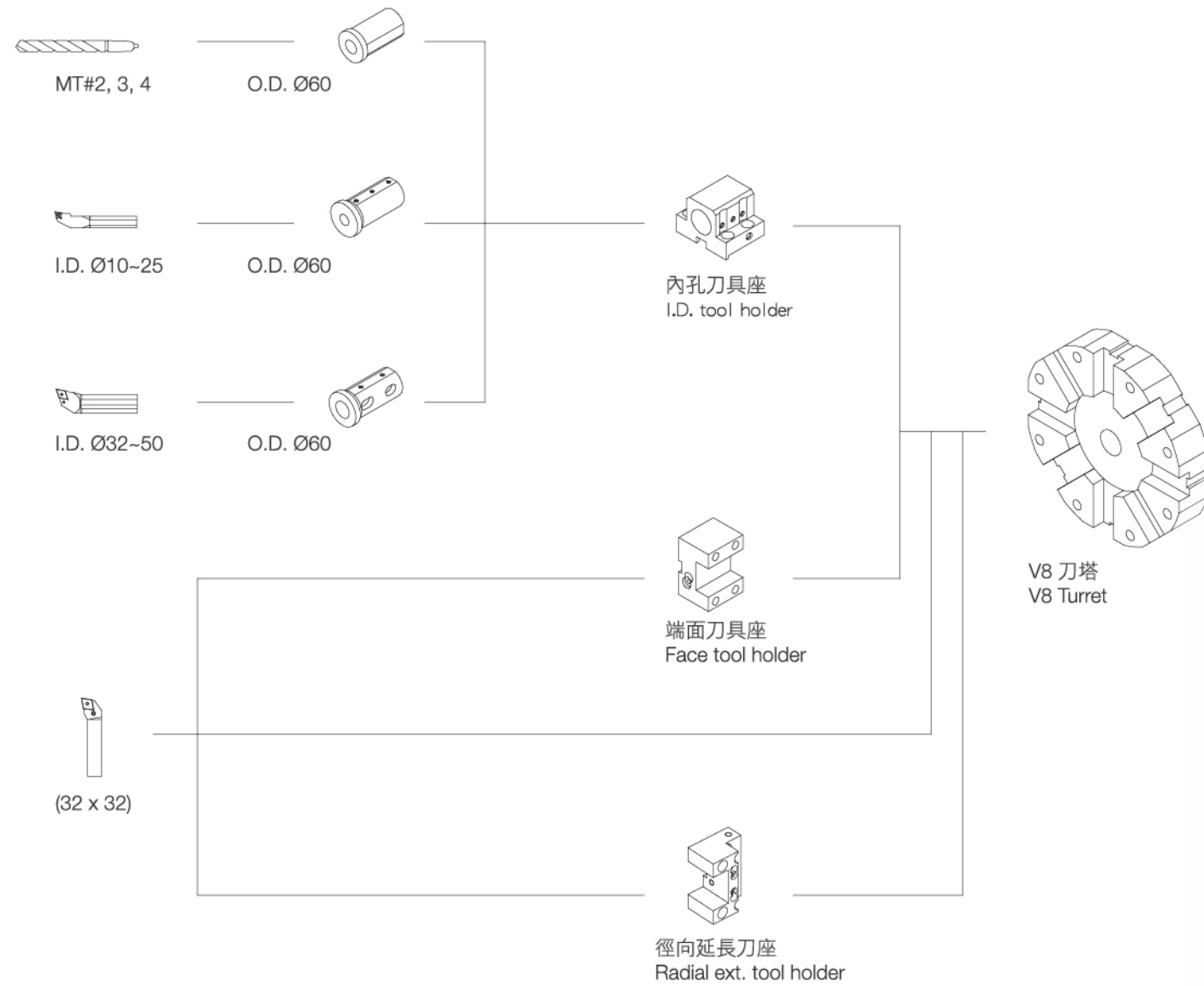
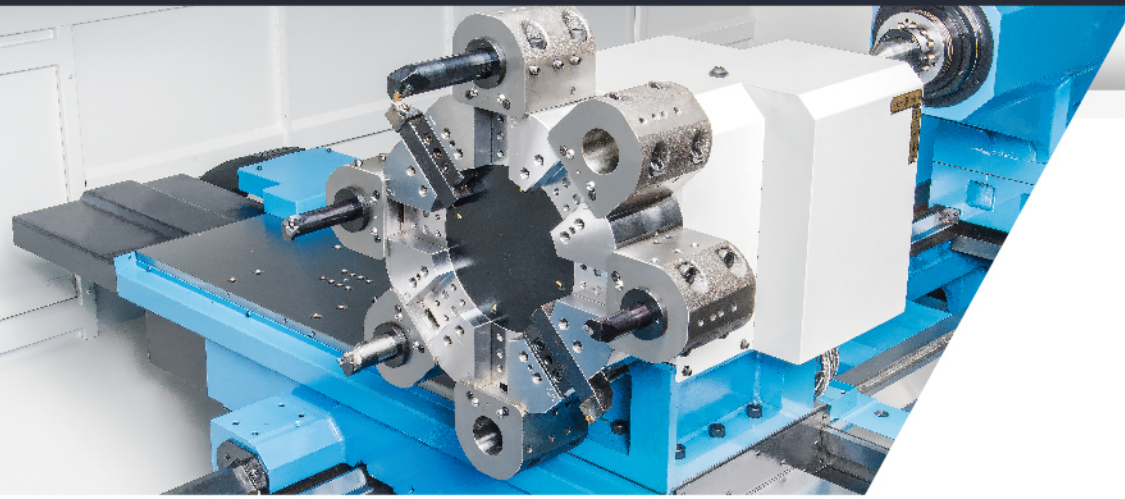

CL-68 (Ø181, Ø255, Ø375)

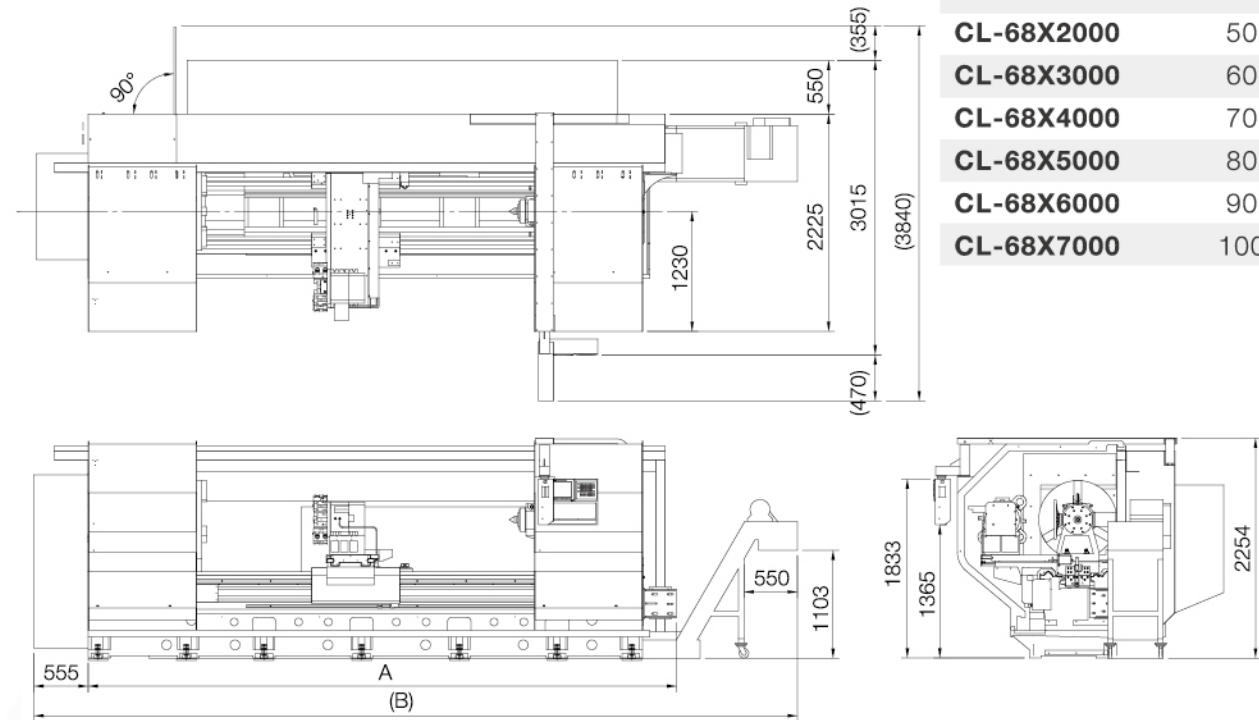

機型 Model	A	(B)
CL-68X1000	4025	5820
CL-68X2000	5025	6820
CL-68X3000	6025	7820
CL-68X4000	7025	8820
CL-68X5000	8025	9820
CL-68X6000	9025	10820
CL-68X7000	10025	11820

CL-78 (Ø181, Ø255, Ø375)

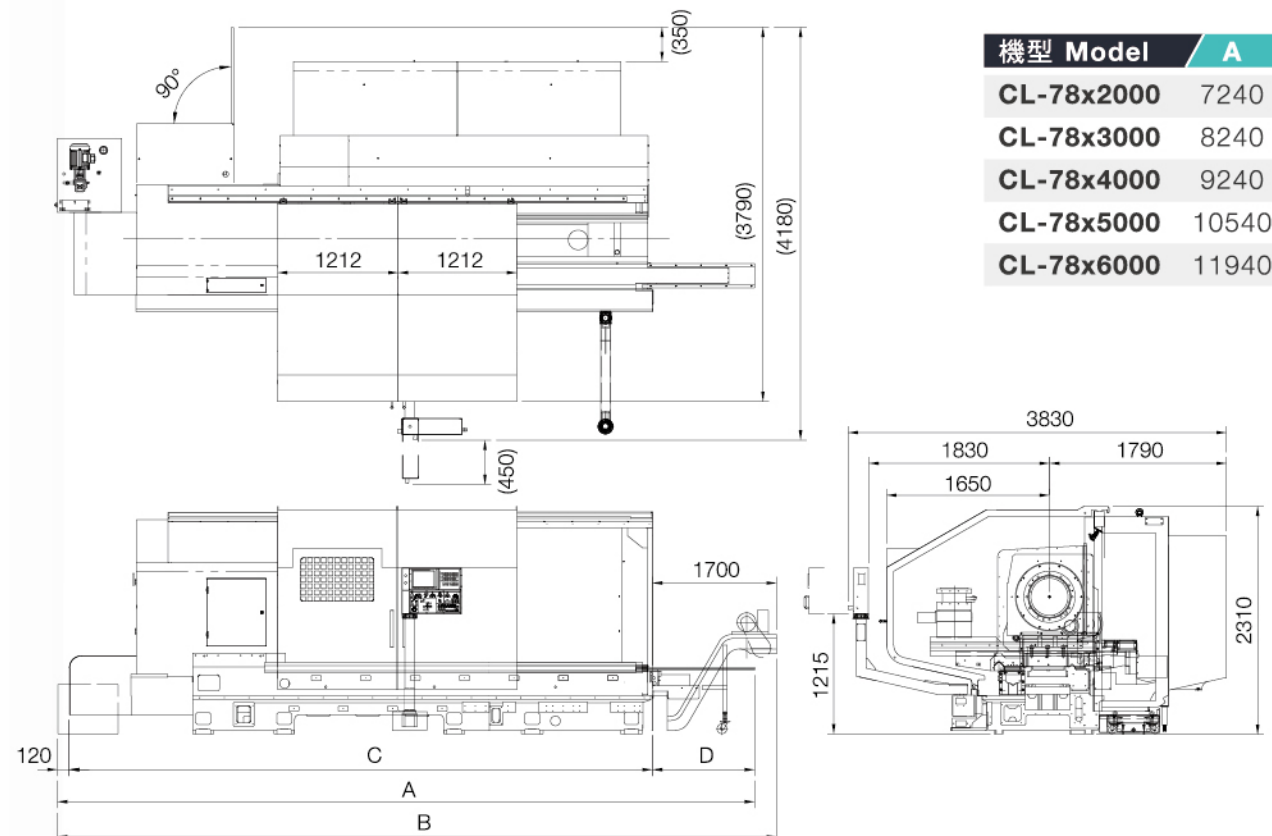

機型 Model	A	B	C	D
CL-78x2000	7240	7745	5775	1345
CL-78x3000	8240	8745	6775	1345
CL-78x4000	9240	9745	7775	1345
CL-78x5000	10540	10745	8775	1675
CL-78x6000	11940	11745	9775	2045



# 機械規格 MACHINE SPECIFICATIONS

項目	ITEM	CL-68	CL-78
床面上旋徑	Swing over bed	Ø1150 mm	Ø1500 mm
鞍面上旋徑	Swing over cross slide	Ø700 mm	Ø900 mm
兩心間距	Distance between centers	1020, 2020, 3020, 4020, 5020, 6020, 7020 mm	2075, 3075, 4075, 5075, 6075 mm
床面寬度	Width of bed	725 mm	1000 mm
主軸孔徑 (鼻端, 轉速)	Spindle bore (nose & speed)	Ø181 mm (A2-15, 6~650 r.p.m.) Ø255 mm (A2-15, 6~650 r.p.m.) Ø375 mm (A2-20, 4~500 r.p.m.) Ø530 mm (A2-28, 2~300 r.p.m.)	
主軸變速檔數	Number of spindle speed range	2	
主軸馬達 (30分/連續)	Spindle motor (30 min./cont.)	α40i (60 HP / 50 HP)	
刀塔	標準選項	Turret	Standard
	選購		Option
X軸移動量	Travel of X axis	560 mm	735 mm
Z軸移動量	Travel of Z axis	950, 1950, 2950, 3950, 4950, 5950, 6950 mm	1975, 2975, 3975, 4975, 5975 mm
進給速度	Rapid traverse (X, Z)	6 m/min	
伺服馬達	Servo motor	X: α22i (5.3 HP), Z: α40i (8 HP)	
尾座心軸移動量	Travel of tailstock quill	180 mm	
尾座心軸直徑	Diameter of tailstock quill	240 mm	
尾座心軸斜度	Taper of tailstock quill	MT#6	
油壓馬達	Hydraulic motor	2 HP	3 HP
冷卻泵浦	Coolant pump	1 HP	
機械長度	Length of machine	5820, 6820, 7820, 8820, 9820, 10820, 11820 mm	7745, 8745, 9745, 10745, 11745 mm
機械寬度	Width of machine	3023 mm	3830 mm
機械高度	Height machine	2254 mm	2310 mm
機械重量	Weight of machine	11800, 13260, 15110, 16980, 18850, 20730, 24000 kg	14260, 16110, 17980, 19850, 21730 kg

- 以上規格如有變更恕不另行通知。
- 兩心間距會因主軸孔徑不同而改變。
- X軸移動量會因不同刀塔而改變。
- 機械長度含鐵屑輸送機。
- 詳細規格數據依報價為主。

- Specifications are subject to change without notice.
- Distance between centers will be changed according to spindle bore specification.
- X axis travel will be changed according to different turret specification.
- Machine length does not include chip conveyor.
- Detail specification depends on quotation.

## 標準配備及附件

- 電腦FANUC Oi TF
- 彩色螢幕10.4"
- 主軸馬達60 HP, α40i
- 主軸孔徑Ø181, Ø255, Ø375或Ø530 mm (僅適用於CL-78機型)
- 立式V8刀塔, 刀具座及刀套
- 副主軸式尾座及固定頂針MT#6
- 油壓系統
- 冷卻水槽及冷卻系統
- 鐵屑輸送機
- 雙門及擋屑板
- 工作燈
- 工具箱及調整工具

## STANDARD EQUIPMENT & ACCESSORIES

- Controller FANUC Oi TF
- Color LCD 10.4"
- Spindle motor 60 HP, α40i
- Spindle bore Ø181, Ø255, Ø375 or Ø530 mm (only for CL-78)
- Vertical 8-station turret, tool holders & sockets
- Tailstock with built-in-center & dead center MT#6
- Hydraulic system
- Coolant tank & coolant system
- Chip conveyor
- Double door & splash guard
- Work light
- Tool box with adjusting tool

## 特別配備及附件

- 主軸機械式定位
- 中空油壓三爪夾頭
- 手動三爪連動夾頭
- 手動四爪夾頭
- 空壓夾頭
- 臥式H4刀塔不含刀具座及刀套
- 臥式H6刀塔不含刀具座及刀套
- 立式V12動力刀塔不含刀具座及刀套
- 搪孔刀座不含刀桿
- CL-68有4種夾持範圍的軸承中心架分別為Ø40~Ø220 mm, Ø210~Ø390 mm, Ø350~Ø520 mm, Ø520~Ø700 mm
- CL-68滾輪架: Ø580~Ø850 mm

## OPTIONAL EQUIPMENT & ACCESSORIES

- Spindle mechanical orientation
- 3-jaw hollow hydraulic chuck
- 3-jaw manual scroll chuck
- 4-jaw manual independent chuck
- Pneumatic power chuck
- Horizontal 4-station turret
- Horizontal 6-station turret
- V12 driven tool system without tool holder & sockets
- Boring attachment without boring bar

- CL-78有2種夾持範圍的軸承中心架分別為Ø450~Ø655 mm, Ø650~Ø800 mm
- CL-78: 滾輪架及墊塊 Ø600~Ø850 mm, Ø800~Ø1070 mm
- 變壓器
- CL-68: there are four different clamping ranges for steady rests with roller jaw: Ø40~Ø220 mm, Ø210~Ø390 mm, Ø350~Ø520 mm and Ø520~Ø700 mm
- CL-68: supporter with roller and pad, clamping range Ø580~Ø850 mm.
- CL-78: there are two different clamping ranges for teady rests with roller jaw: Ø450~Ø655 mm and Ø650~800 mm
- CL-78: supporter with roller and pad, clamping range Ø600~Ø850 mm and Ø800~Ø1070 mm
- Transformer

## 特別附件 OPTIONAL ACCESSORIES



H4刀座 (CL-78)  
H4 tool post for CL-78



V8+H6刀塔  
V8+H6 turret

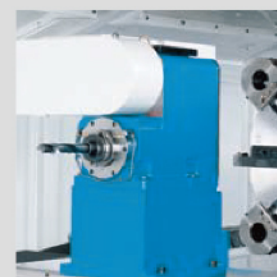

側鑽銑裝置 (CL-78)  
Side drilling & milling attachment for CL-78

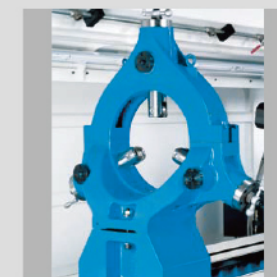

中心架 (CL-68)  
Steady rest for CL-68



中心架 (CL-78)  
Steady rest for CL-78