

www.kinwa-lathe.com

FLAT BED CNC LATHE

平台式CNC車床



CL-38 / CL-58 series

精度準確 品質卓越

SUPREME ACCURACY. EXCELLENT QUALITY.

KINWA
金和車床

金和精密股份有限公司
CHIN HUNG MACHINERY CO., LTD.

台中市大雅區田心街10號
No.10, Tianxin St., Daya Dist.,
Taichung City 428, Taiwan
Tel: +886-4-25663114 · 25666113
Fax: +886-4-25665254
E-mail: ufkinwa@ms15.hinet.net
www.kinwa-lathe.com



穩重的機器結構 專為重切削而打造

MASSIVE MACHINE STRUCTURE!
BUILT FOR HEAVY CUTTING!

FLAT BED CNC LATHE 平台式CNC車床



懸吊式操作箱

懸吊式操作箱可以移動到最佳操作位置，並且可以作角度旋轉，使操作更方便。

PENDANT TYPE OPERATION BOX

The pendant type operation box can be moved to an appropriate operation position and can be swiveled for increasing convenience in operation.

油壓系統

油壓系統採用高級元件組成，性能穩定、低溫升、低噪音，可耐長時間連續作業。

HYDRAULIC SYSTEM

The hydraulic system consists of high quality components with outstanding features for stable performance, low thermal growth, low noise and suitable for long time continuous operation.

特仕版 SPECIAL EDITION



機型 MODEL CL-38 HP / CL-58 HP

- 平台式機體結構，展現完美剛性，機體不變形。
- 橫向滑座採用鳩尾槽式滑道，直線精度高。
- 尾座可安裝夾頭，兼具副主軸功能。
- 最大主軸孔徑可達 $\text{Ø}375$ mm (CL-58)。
- 強力主軸馬達驅動，適合重切削。
- V8油壓刀塔為標準配備。
- 雙門式鈹金。

- The flat bed machine structure presents perfect rigidity and without structural deformation.
- The cross slide moves on the dovetailed slide ways for high straightness accuracy.
- The tailstock can be mounted with a chuck to achieve a sub-spindle function.
- Max. spindle bore is of up to $\text{Ø}375$ mm (CL-58).

- Powerful spindle motor drive makes the machine ideal for heavy cutting.
- V8 hydraulic turret is standard.
- Equipped with double door.

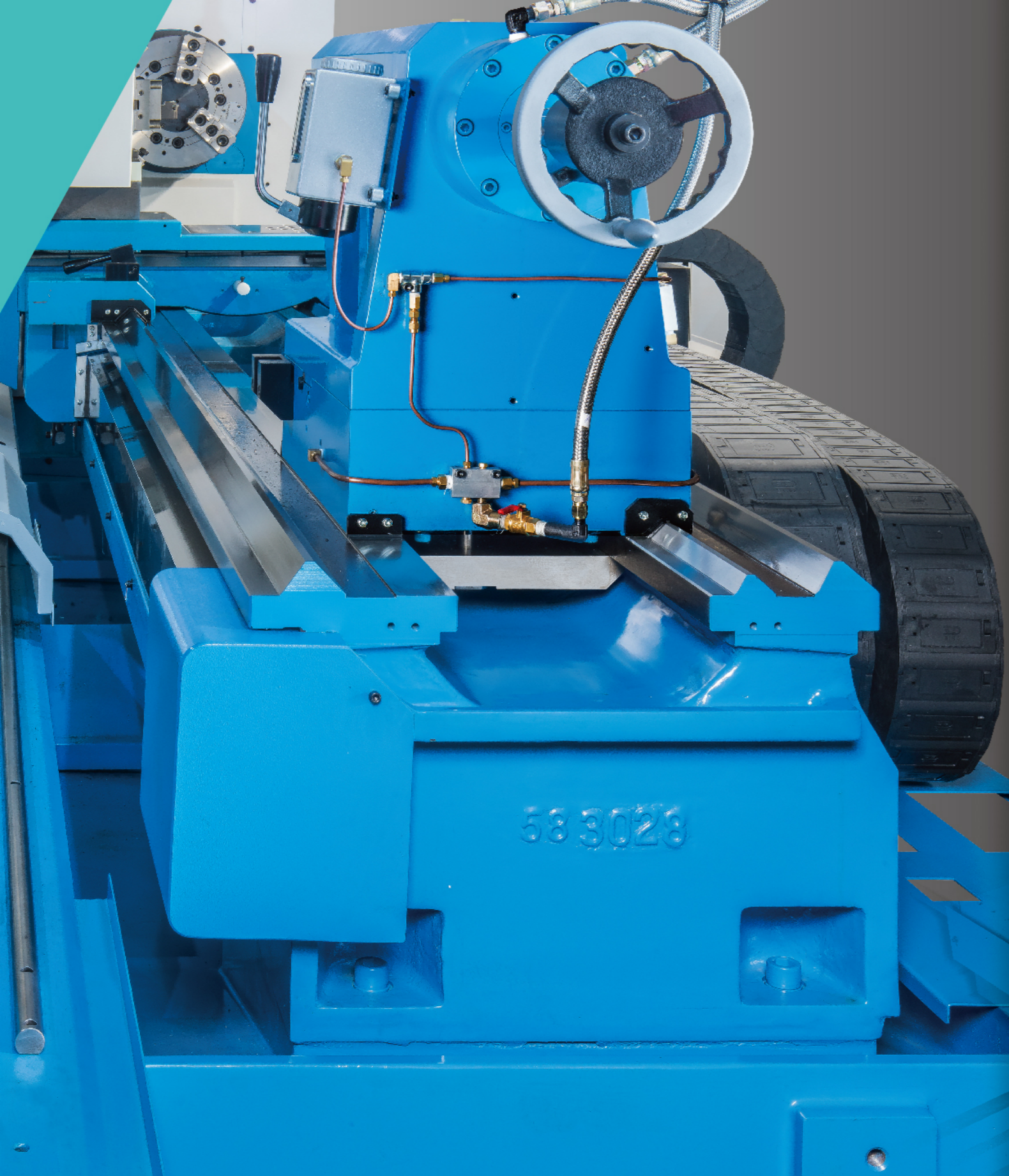

床身與底座

- 床身與底座採用高級鑄鐵製成，並經應力消除，多年使用後，床身仍無變形之慮。
- 床身滑道經熱處理硬化 (硬度高達HS70)，再經精密研磨，具有優異的耐磨耗性。
- 床身具有三個“V”型滑道及一個“平面”型滑道，以確保加工之精度。
- 鞍座滑道為二個“V”型滑道，直線精度高。

CONSTRUCTED BED AND BASE

- The bed and base are manufactured from high quality cast iron, and stress relieved for deformation – free performance year after year.
- Bed slideways are hardened (hardness HS70^o) and precision ground, featuring outstanding wear-resistance.
- The bed is designed with three “V” and one “flat” slideways to ensure machining accuracy.
- The saddle moves on double “V” slideways to achieve high straightness accuracy.

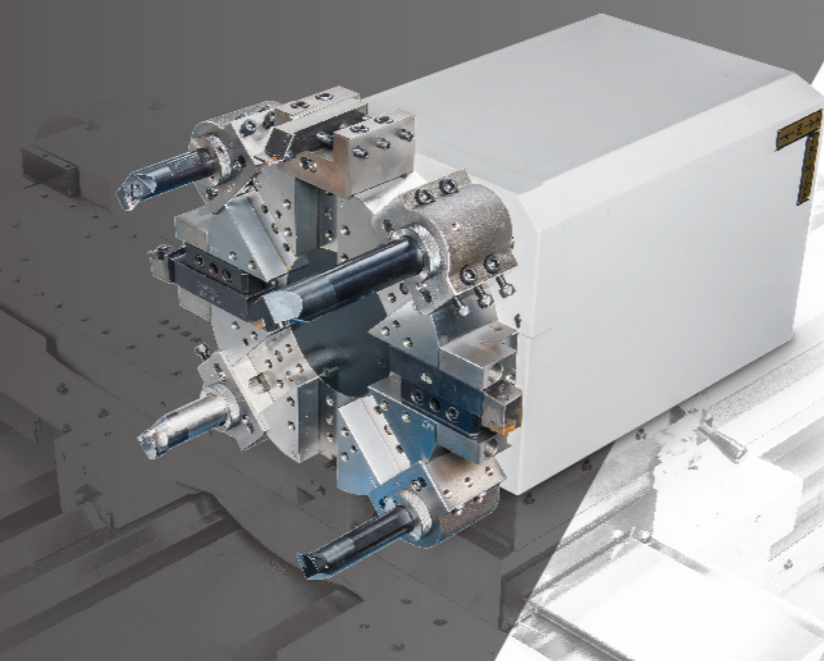

V8油壓刀塔

- 立式V8油壓刀式為標準配備。
- 選刀方式為雙向，任意式選刀。
- 最大刀具尺寸:
外徑刀□25 mm (CL-38) / □32 mm (CL-58)
內徑刀Ø40 mm (CL-38) / Ø50mm (CL-58)

V8 HYDRAULIC TURRET

- V8 hydraulic turret is a standard accessory.
- Tool selection method is bi-directional, random tool selection.
- Max. tool size:
O.D. tool □25 mm (CL-38) / □32 mm (CL-58)
I.D. tool Ø40 mm (CL-38) / Ø50 mm (CL-58)



主軸箱

- 高剛性主軸箱結構。在重切削時，更凸顯其非凡的穩定性。
- 主軸箱內部齒輪採用高精度之日本JIS一級齒輪，運轉順暢、低噪音。
- 主軸箱潤滑為泵浦強制潤滑系統。

HEADSTOCK

- The headstock is a highly rigid structure, which offers superb stability in heavy cutting.
- All gears in the headstock employ high precision Japan JIS class 1 gears, assuring smooth with low-noise.
- Headstock lubrication is a forced lubrication system operated by a pump.

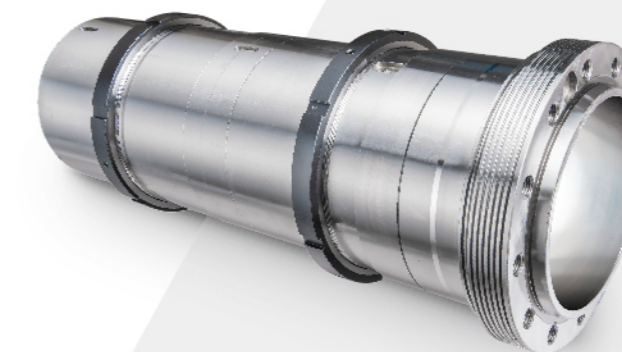

主軸

- 主軸孔徑選擇:
CL-38: Ø120, Ø186 mm。
CL-58: Ø120, Ø186, Ø258, Ø375 mm。
- 主軸採用P級斜度滾柱軸承。重切削時，穩定性優異。

SPINDLE

- Choice of spindle bore:
CL-38: Ø120, Ø186 mm
CL-58: Ø120, Ø186, Ø258, Ø375mm.
- The spindle associate with P class taper roller bearing that presents outstanding stability in heavy cutting.

最佳化結構設計
穩重！ 順暢！

OPTIMIZED STRUCTURE DESIGN
MAXIMUM STABILITY! SUPERB SMOOTHNESS!



鞍座及橫向滑座

- X, Z軸採用個別伺服馬達驅動，並經由精密滾珠螺桿傳動。進給順暢、定位精準。
- 橫向滑座之滑道採用鳩尾槽式設計。滑動面經硬化熱處理，再經精密研磨，耐磨耗性佳。

CARRIAGE AND CROSS SLIDE

- X, Z- axis are driven by individual servo motor and transmitted through high precision ball screws, that provide extremely smooth feed and high positioning accuracy.
- The cross slide moves on dovetail slide ways. Sliding surfaces are hardened and precision ground as well as providing outstanding wear-resistance.

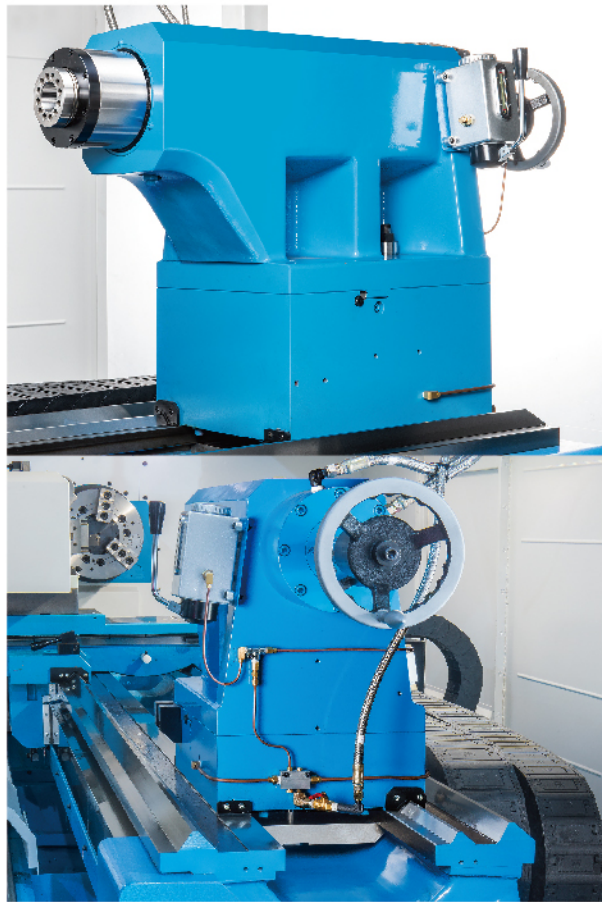

副主軸式尾座

- 移動採用油壓及手動驅動，使工件裝卸快速、方便。
- 可安裝夾頭，具有副主軸功能。
- 尾座心軸可使用MT#5之固定頂心。
- Ø150 mm心軸直徑，適合支撐大工件。

TAILSTOCK WITH SUB-SPINDLE FUNCTION

- The tailstock quill movement is driven by hydraulic power or manual for fast and convenient working loading and unloading.
- The tailstock quill can be mounted with a chuck with sub-spindle function.
- The quill a MT#5 dead center.
- Ø150 mm quill diameter makes it suitable to hold a large workpiece.

主軸轉速/馬達輸出曲線圖 SPINDLE SPEED/OUTPUT DIAGRAM

CL-38 / CL-58 Ø120孔徑 spindle bore

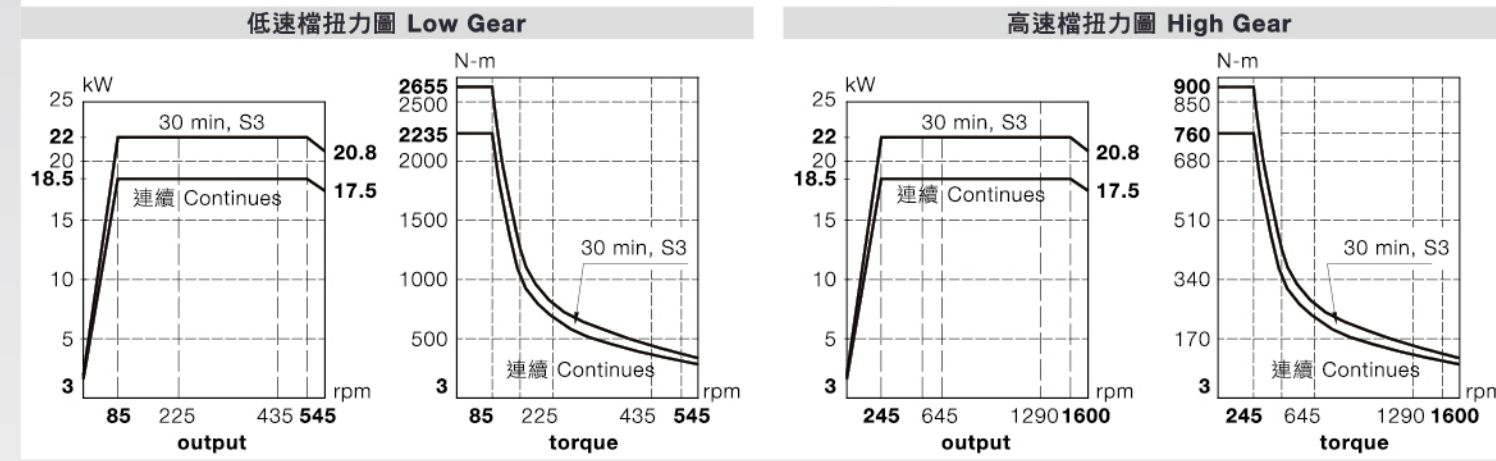

CL-38 / CL-58 Ø186孔徑 spindle bore

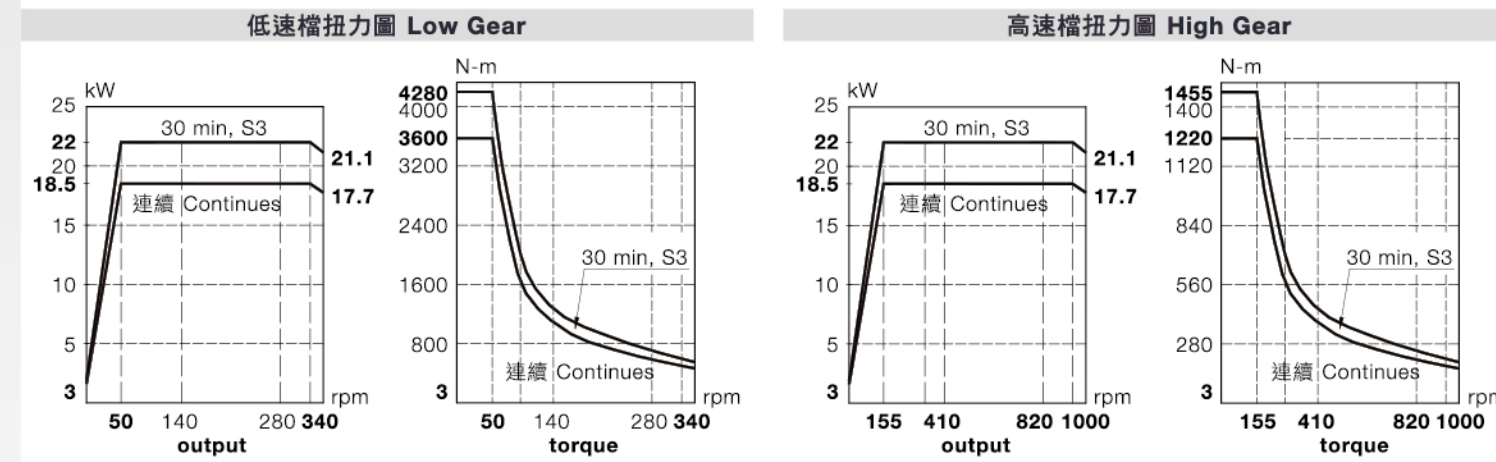

CL-58 Ø258孔徑 spindle bore (FANUC α P50i / 6000)

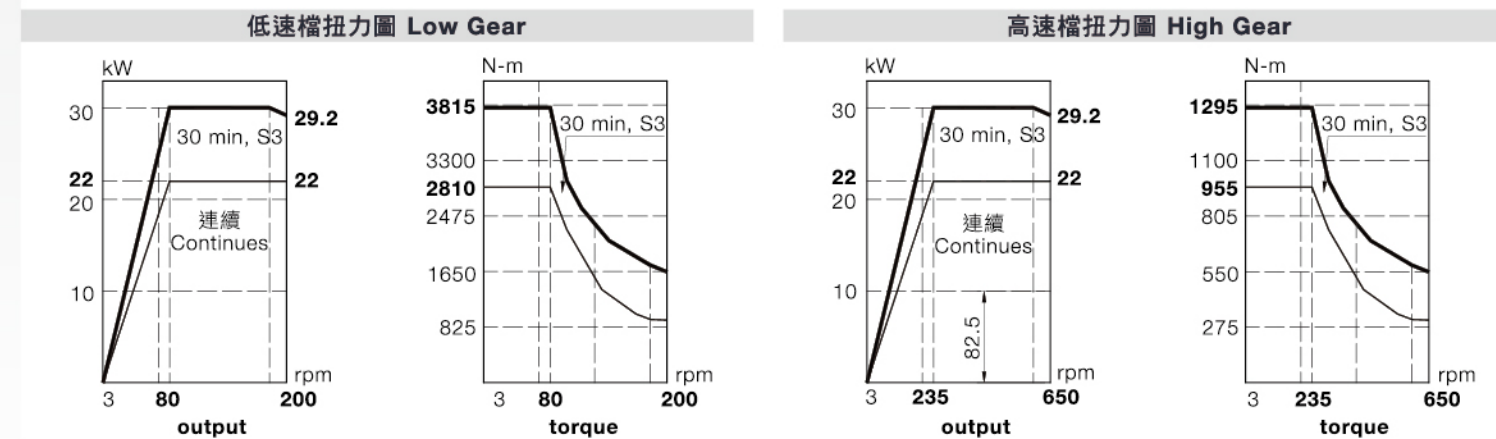

CL-58 Ø375孔徑 spindle bore (FANUC α P50i / 6000)

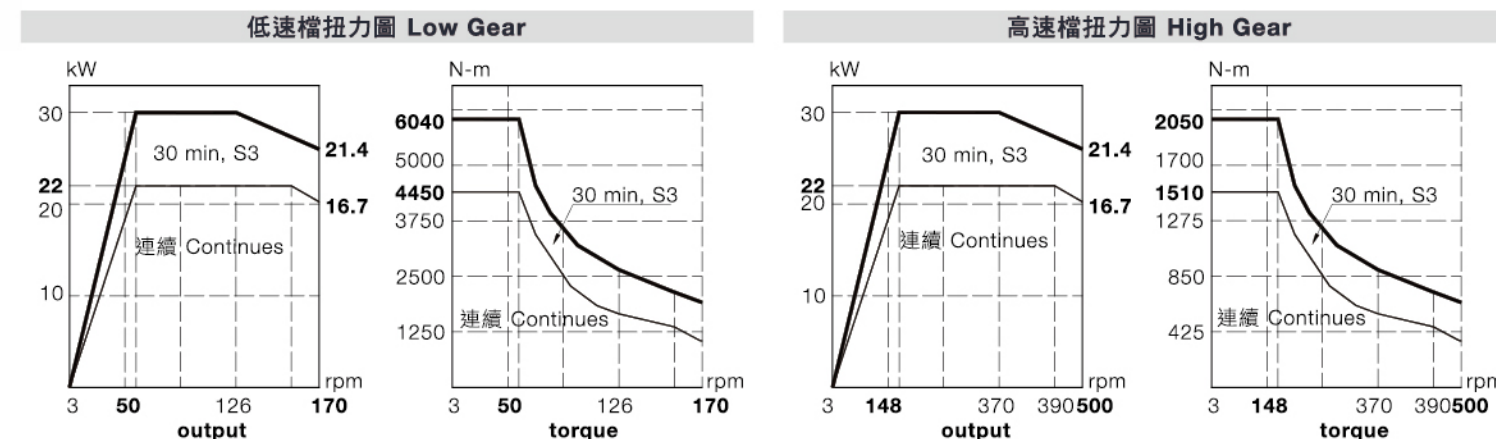

工作行程圖 WORKING TRAVEL DIAGRAM

CL-38 V8 (□25)

機型 Model	Z軸行程 Z axis travel	A (鼻端到尾座頂心) Dist. bet. centers (Ø120 bore)		兩心距=A-C Dist. bet. centers=A-C
		Ø120孔徑 spindle bore	Ø186孔徑 spindle bore	
CL-38X1000	950	1155	1110	1055
CL-38X1500	1450	1655	1610	1555
CL-38X1950	1950	2155	2110	2055
CL-38X3220	3220	3435	3390	3335
CL-38X4170	4170	4385	4340	4285

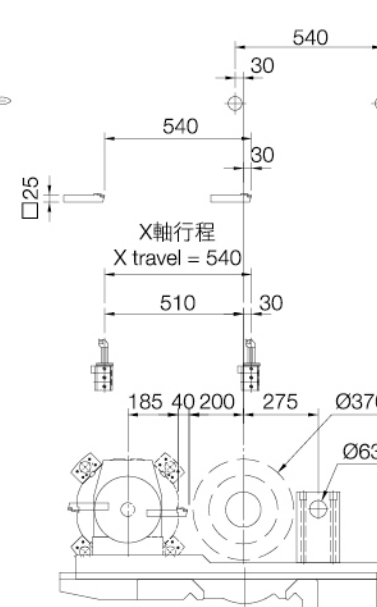
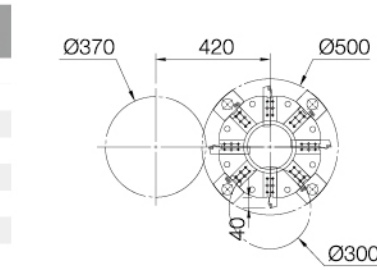
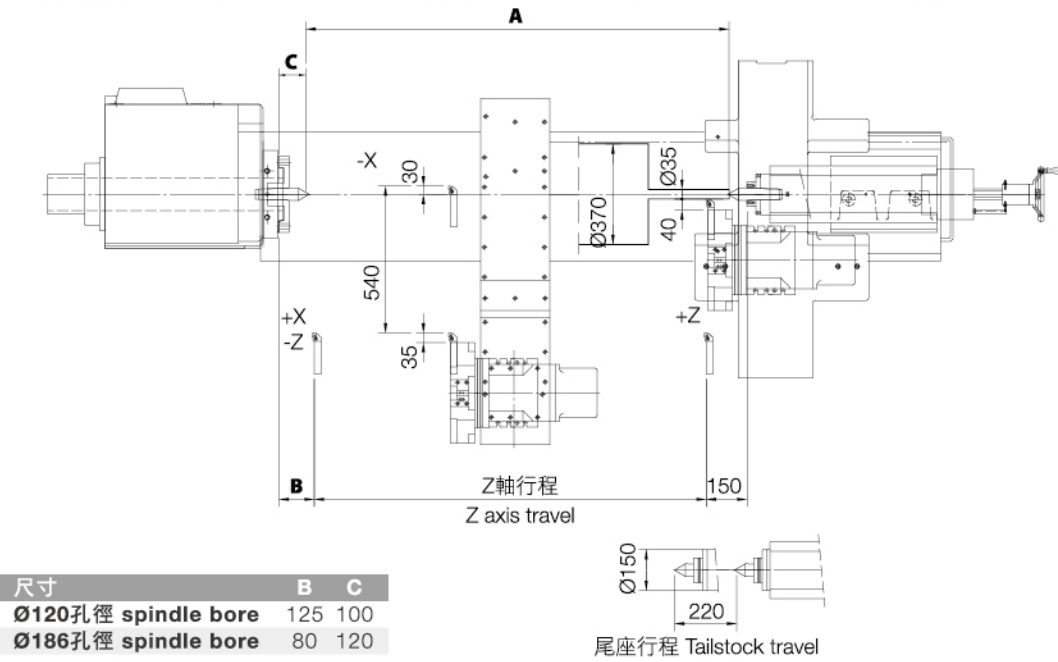

CL-58 搭配CLT-160-V8刀塔 (□32) CL-58 equipped with CLT-160-V8 turret (□32)

機型 Model	Z軸行程 Z axis travel	A (鼻端到尾座頂心) Dist. bet. centers (Ø120 bore)				兩心距=A-C Dist. bet. centers=A-C
		Ø120孔徑 spindle bore	Ø186孔徑 spindle bore	Ø258孔徑 spindle bore	Ø375孔徑 spindle bore	
CL-58X1000	950	1115	1070	1075	1090	1015
CL-58X1500	1450	1615	1570	1575	1590	1515
CL-58X2000	1950	2115	2070	2075	2090	2015
CL-58X3000	3220	3395	3350	3355	3370	3295
CL-58X4000	4170	4345	4300	4305	4320	4245
CL-58X5000	5360	5625	5580	5585	5600	5525
CL-58X6000	6165	6430	6385	6390	6405	6330

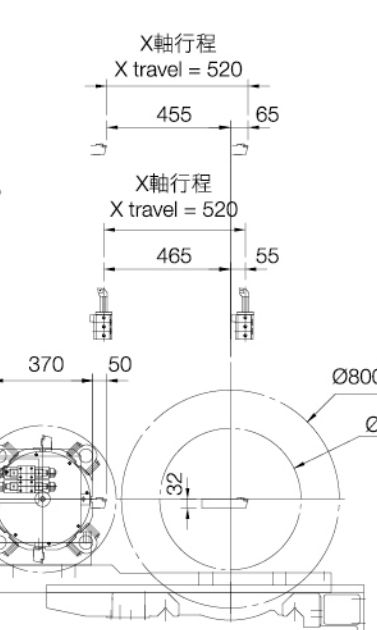
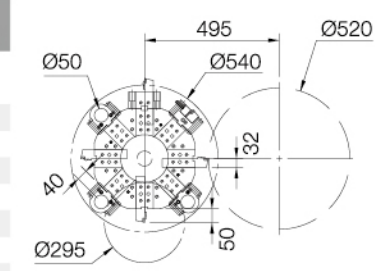
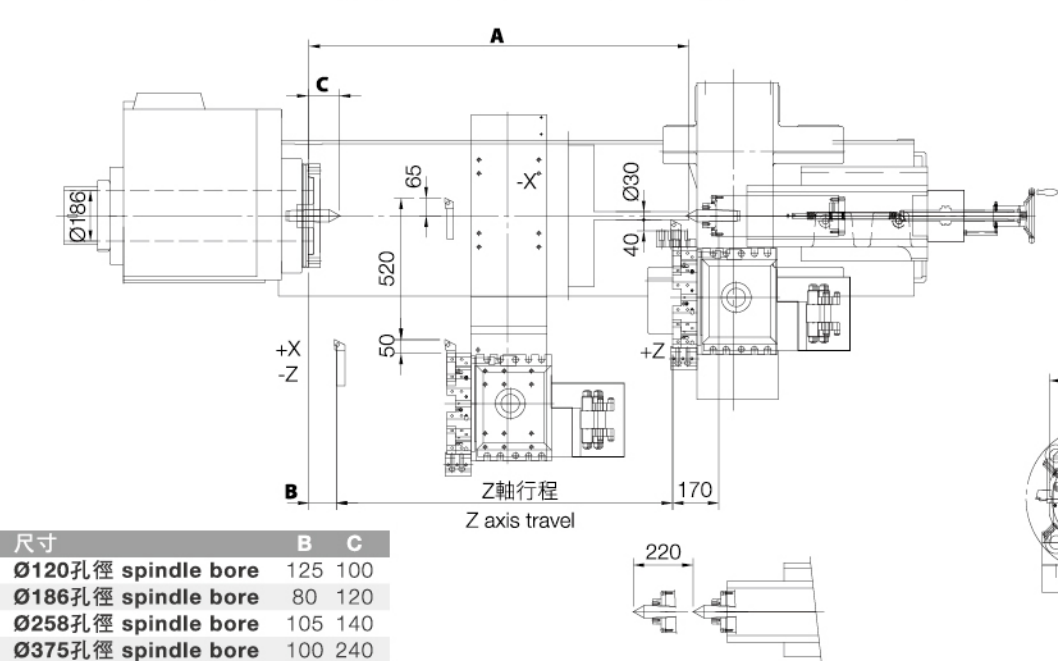

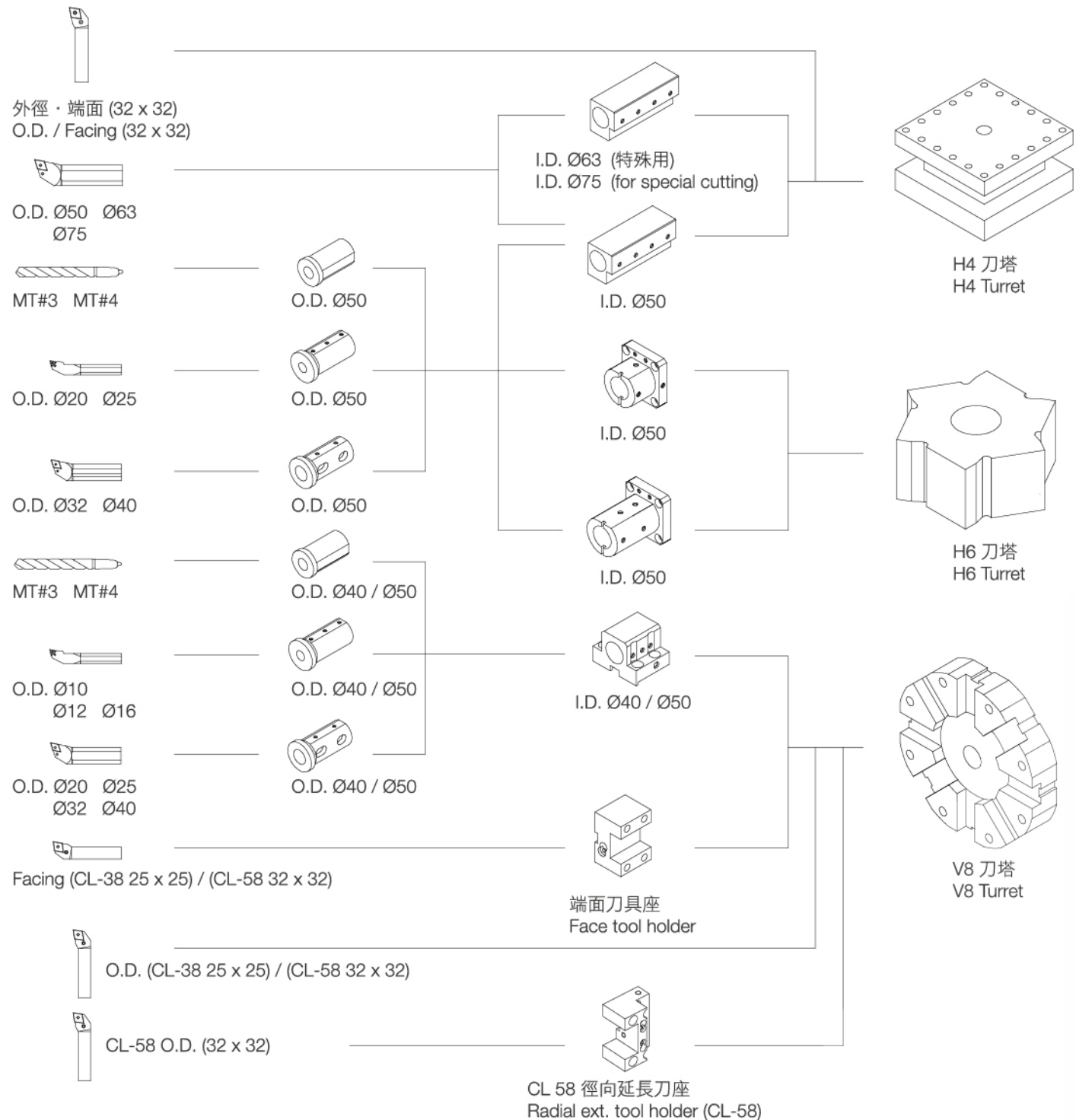
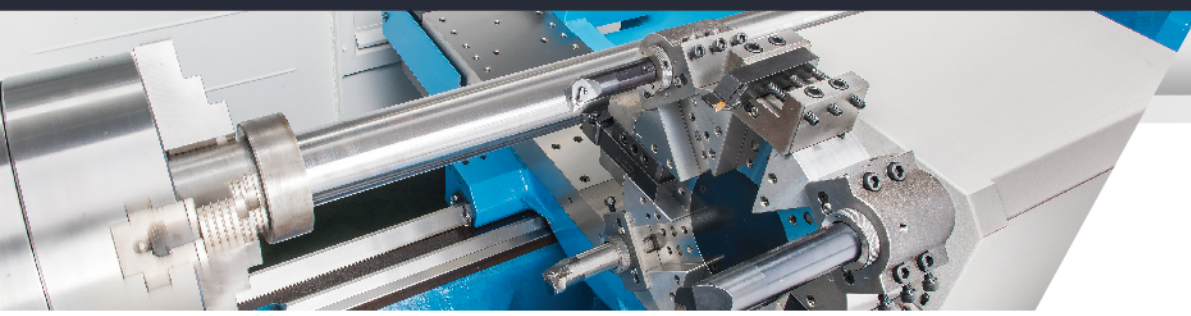

CL-38

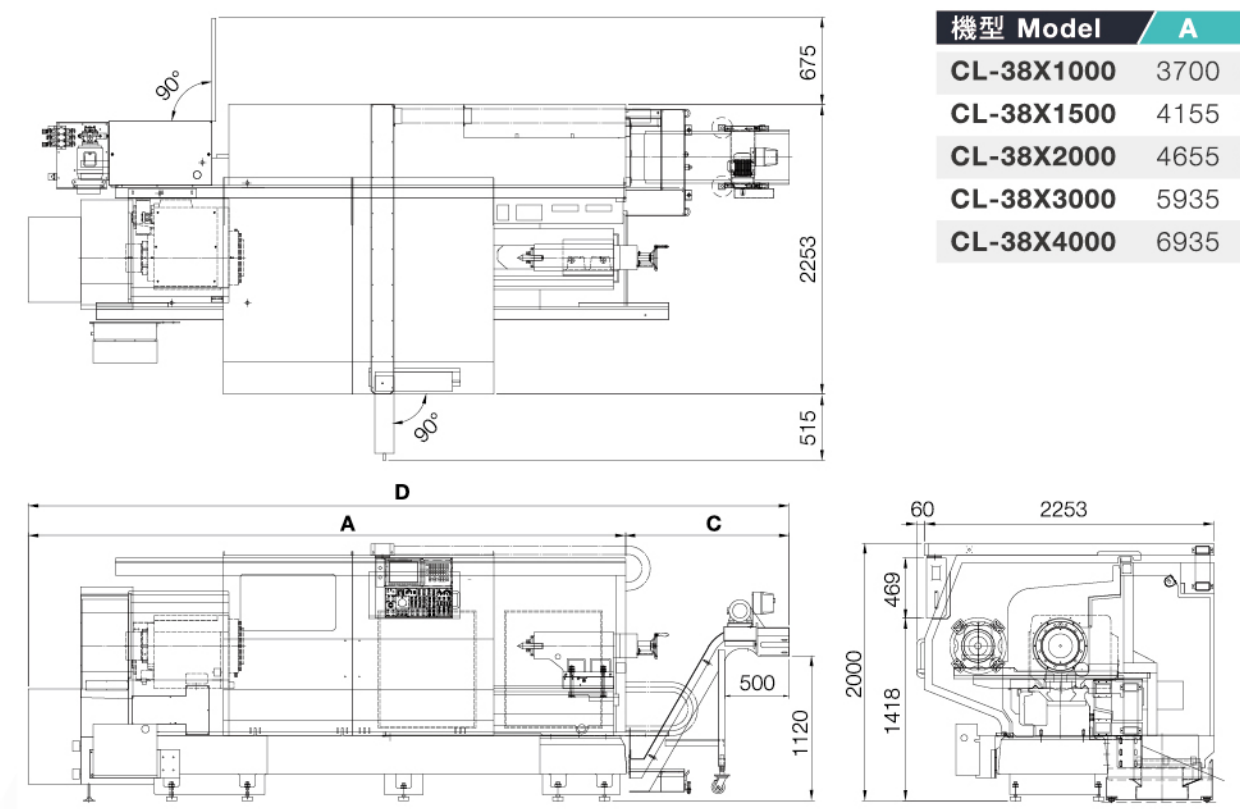

機型 Model	A	B	C	D
CL-38X1000	3700	385	1250	4950
CL-38X1500	4155	385	1250	5405
CL-38X2000	4655	385	1250	5905
CL-38X3000	5935	185	1050	6985
CL-38X4000	6935	185	1250	8185

CL-58

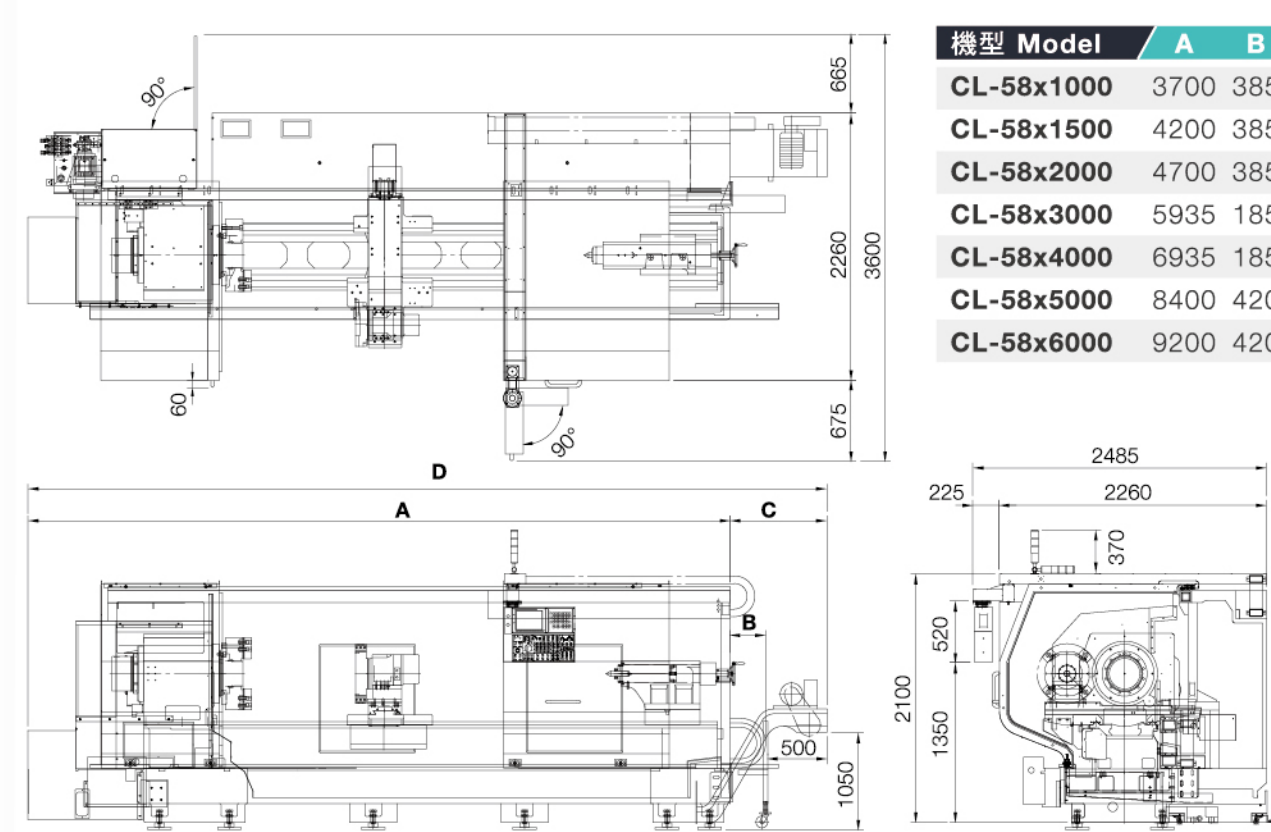

機型 Model	A	B	C	D
CL-58x1000	3700	385	1250	4950
CL-58x1500	4200	385	1250	5450
CL-58x2000	4700	385	1250	5950
CL-58x3000	5935	185	1050	6985
CL-58x4000	6935	185	1250	8185
CL-58x5000	8400	420	1700	10100
CL-58x6000	9200	420	1700	10900

機械規格 MACHINE SPECIFICATIONS

項目	ITEM	CL-38	CL-58
床面上旋徑	Swing over bed	Ø660 mm	Ø900 mm
鞍面上旋徑	Swing over cross slide	Ø370 mm	Ø520 mm
兩心間距	Distance between centers	1055, 1555, 2055, 3335, 4285 mm	1015, 1515, 2015, 3295, 4245, 5525, 6330 mm
床面寬度	Width of bed	460 mm	560 mm
主軸孔徑 (鼻端, 轉速)	Spindle bore (nose & speed)	Ø120 mm (A2-11, 6~1600 r.p.m.)	Ø120 mm (A2-11, 6~1600 r.p.m.)
		Ø186 mm (A2-15, 3~1000 r.p.m.)	Ø186 mm (A2-15, 3~1000 r.p.m.)
主軸變速檔數	Number of spindle speed range	2	
主軸馬達 (30分/連續)	Spindle motor (30 min./cont.)	αP40i (30 HP / 25 HP)	αP40i (30 HP / 25 HP)
			αP50i (40 HP / 30 HP) (選配 opt.)
刀塔	標準選項	Turret	Standard
			Option
	選購		
X軸移動量	Travel of X axis	540 mm	520 mm
Z軸移動量	Travel of Z axis	950, 1450, 1950, 3220, 4170 mm	950, 1450, 1950, 3220, 4170, 5360, 6165 mm
進給速度	Rapid traverse (X, Z)	10 m/min	
伺服馬達	Servo motor	X: α12is (3.6 HP), Z: α22iF (5.4 HP)	
尾座心軸移動量	Travel of tailstock quill	220 mm	
尾座心軸直徑	Diameter of tailstock quill	150 mm	
尾座心軸斜度	Taper of tailstock quill	MT#5	
油壓馬達	Hydraulic motor	2 HP	
冷卻泵浦	Coolant pump	1 HP	
機械長度	Length of machine	4950, 5405, 5905, 6985, 8185 mm	4950, 5450, 5950, 6985, 8185, 10100, 10900 mm
機械寬度	Width of machine	2313 mm	2485 mm
機械高度	Height of machine	2000 mm	2100 mm
機械重量	Weight of machine	6400, 6800, 7400, 8400, 10100 kg	7300, 9200, 10800, 11800, 13200, 14500 kg

- 以上規格如有變更恕不另行通知。
- 兩心間距會因主軸孔徑不同而改變。
- X軸移動量會因不同刀塔而改變。
- 機械長度含鐵屑輸送機。
- 詳細規格數據依報價為主。

- Specifications are subject to change without notice.
- Distance between centers will be changed according to spindle bore specification.
- X axis travel will be changed according to different turret specification.
- Machine length does not include chip conveyor.
- Detail specification depends on quotation.

標準配備及附件

- 電腦FANUC 0iTF
- 彩色螢幕10.4"
- 主軸馬達30 HP, αP40i
- 立式V8刀塔, 刀具座及刀套
- 主軸孔徑120,186 mm
- 油壓系統
- 冷卻水槽及冷卻系統
- 鐵屑輸送機
- 雙門及擋屑板
- 工作燈
- 工具箱及調整工具
- 副主軸式尾座及固定頂針MT#5

STANDARD EQUIPMENT & ACCESSORIES

- Controller FANUC 0iTF
- Color LCD 10.4"
- Spindle motor 30 HP, αP40i
- Vertical 8-station turret, tool holders & sockets
- Spindle bore 120, 186 mm
- Hydraulic system
- Coolant tank & coolant system
- Chip conveyor
- Double door & splash guard
- Work light
- Tool box with adjusting tool
- Tailstock with built-in-center & dead center MT#5

特別配備及附件

- 主軸馬達40 HP, αP50i (僅適用於CL-58機型)
- 主軸孔徑258, 375 mm (僅適用於CL-58機型)
- 主軸機械式定位
- 中空油壓三爪夾頭
- 手動三爪連動夾頭
- 手動四爪單動夾頭
- 空壓夾頭
- 臥式H4刀塔, 刀具座及刀套
- 臥式H6刀塔, 刀具座及刀套
- 立式V12動力刀塔不含刀具座及刀套

OPTIONAL EQUIPMENT & ACCESSORIES

- Spindle motor 40 HP, αP50i (only for CL-58)
- Spindle bore 258, 375 mm (only for CL-58)
- Spindle mechanical orientation
- 3-jaw hollow hydraulic chuck
- 3-jaw manual scroll chuck
- 4-jaw manual independent chuck
- Pneumatic power chuck
- Horizontal 4-station turret, tool holders & sockets
- Horizontal 6-station turret, tool holders & sockets
- Power tool turret 12T without tool holder & sockets

- 快換刀架
- 搪孔刀座不含刀桿
- 軸承中心架Ø40~235 mm (CL-38)
- 軸承中心架Ø190~405 mm (CL-38)
- 軸承中心架Ø90~300 mm (CL-58)
- 軸承中心架Ø290~500 mm (CL-58)
- 手動跟刀架
- 變壓器

- Quick change tool post
- Boring attachment without boring bar
- Steady rest with roller jaw, Ø40~235 mm (CL-38)
- Steady rest with roller jaw, Ø190~405 mm (CL-38)
- Steady rest with roller jaw, Ø90~300 mm (CL-58)
- Steady rest with roller jaw, Ø290~500 mm (CL-58)
- Manual follow rest
- Transformer

特別附件 OPTIONAL ACCESSORIES

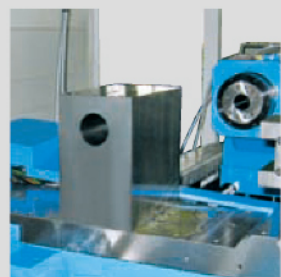

搪孔刀座 (不含刀桿) (選配)
Boring attachment (without boring bar) (opt.)

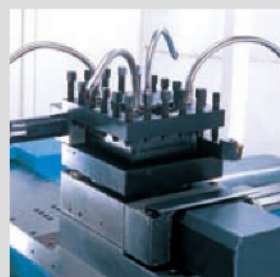

伺服型H4刀座
Servo type H4 tool post

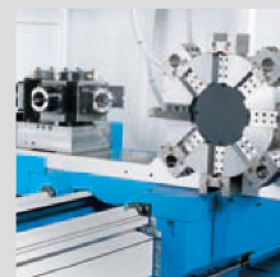

V8+H6刀塔
V8+H6 turret

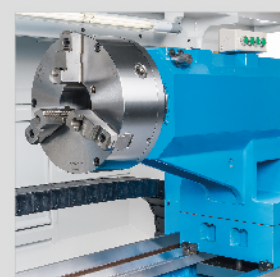

夾頭式副主軸尾座 (選配)
Chuck type tailstock with built-in-center (opt.)



中心架 (選配)
Steady rest (opt.)



油壓夾頭 (選配)
Hydraulic chuck (opt.)



手動跟刀架 (選配)
Manual follow rest (opt.)