

機械外型圖 Dimensional Drawing (mm)

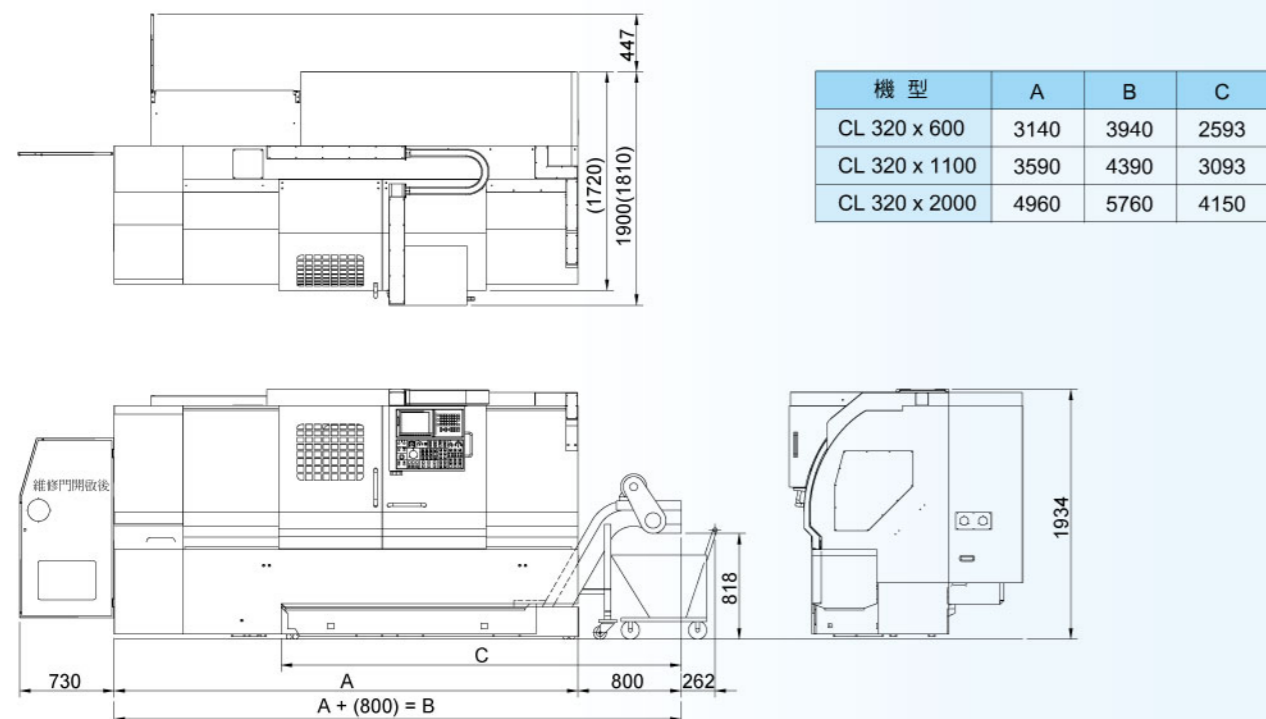

主軸結構與主要尺寸 Structure and dimensions of spindle

主軸轉速/馬達輸出曲線圖 Spindle speed / Output diagram

CL320A

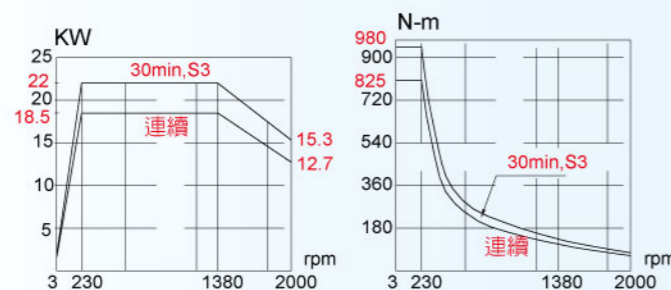
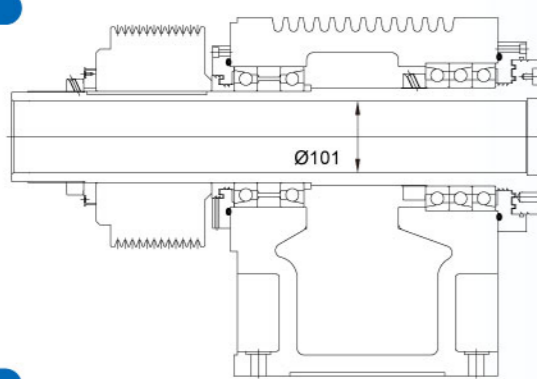

CL320B

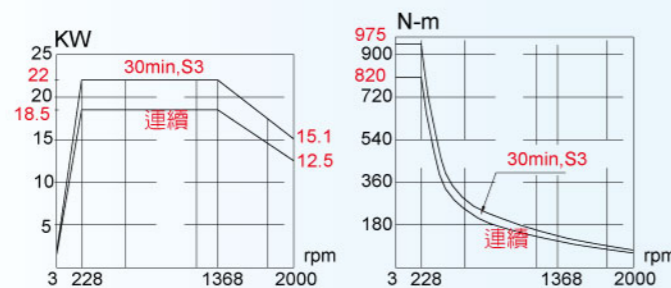
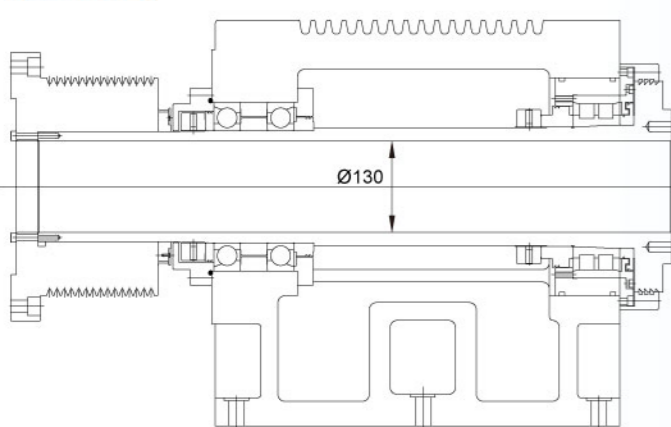

機械規格 Specifications (CL-320)

※ (選購Option)

項目 Item	CL-320A x 600	CL-320A x 1100	CL-320B x 2000
容量 Capacity	床面上旋徑 Swing over bed 550 mm		
	鞍面上旋徑 Swing over carriage 380 mm		
	最大切削直徑 Max. turning diameter 470 mm (※ 動力刀塔 Driven tool system : 300 mm)		
	最大加工長度 Max. cutting length 580 mm 1080 mm 2060 mm ※1990 mm		
移動量 Stroke	X軸 X-axis 240 mm (※ 動力刀塔 Driven tool system : 265 mm)		
	Z軸 Z-axis 590 mm 1090 mm 2070 mm ※2000 mm		
主軸 Spindle	轉速 Speed 25 ~ 2000 rpm 20~2000 rpm		
	主軸鼻端 Spindle nose Ø 220 Ø220 ※Ø300		
	主軸通孔 Spindle bore 101 mm 130 mm		
	夾頭 Chuck 12" 12" ※15"		
	棒材容量 Bar Capacity 90 mm 90 mm ※115 mm		
刀塔 Turret	刀具數 tools V10 (※ V12 動力刀塔 Driven tool system)		
	外徑切削刀具 OD tool shank □ 25 mm		
	內徑切削刀具(最大) ID tool shank(Max.) Ø40 mm		
進給速度 Feed traverse	X 軸 X-axis 20 m/min		
	Z 軸 Z-axis 20 m/min		
尾座 Tailstock	尾座移動量 Tailstock stroke 460 mm 960 mm 1960 mm		
	心軸直徑 Quill diameter Ø112 mm		
	心軸斜度 Quill taper MT4		
	心軸移動量 Quill stroke 100 mm		
馬達 Motor	主軸馬達 (30分) Main motor (30 min.) FANUC αP40i, 30 HP \ 22 kw		
	進給軸馬達 Servo motor X : 3.6 HP \ 2.7 kw, Z : 5.4 HP \ 4 kw		
	油壓單元馬達 Hydraulic unit motor 3 HP \ 2.2 kw		
	切削液馬達 Coolant pump motor 1 HP \ 0.75 kw		
機械尺寸 Machine dimension	機械高度 Height 1934 mm		
	機械長 x 寬 (L x W) 3940 x 1900 mm 4390 x 1900 mm 5760 x 1900 mm		
	機械重量 Weight 5500 kgs 6500 kgs 8950 kgs		

□以上規格如有變更恕不另行通知 / Specifications are subject to change without notice.

標準配備及附件

- FANUC 0/TD控制器
- 主軸馬達30HP, α P40i
- 12"中空油壓三爪夾頭
- 硬爪及軟爪各1組
- 立式10刀刀塔
- 內孔刀座5只
- 端面刀座2只
- 內孔刀套 (M10, 12, 16, 20, 25, 32) 各2只
- 莫氏套筒(MT#2, #3)各1只
- 油壓系統
- 冷卻水槽及高壓冷卻系統
- 活動門及擋屑板
- 可程式副主軸式尾座及油壓心軸
- 固定頂針MT#4
- 工作燈
- 鐵屑輸送機及鐵屑車
- 工具箱及調整工具

Standard equipment & accessories

- FANUC 0/TD controller
- Main motor 30HP, α P40i
- 12" hollow 3-jaw hydraulic chuck
- Hard jaws & soft jaw 1 SET / EACH
- Vertical 10 stations turret
- Boring bar holder 5 PCS
- Facing tool holder 2 PCS
- Boring bar socket 1 SET
- Morse taper socket 1 SET
- Hydraulic system
- Coolant tank & high power coolant system
- Moving door & splash guard
- Programmable tailstock with built-in center and hydraulic quill
- Dead center MT#4
- Work light
- Chip conveyor & chip bucket
- Tool box & adjusting tools

選購配備及附件

- 15"中空油壓三爪夾頭 (CL-320B)
- 外徑刀座
- 立式12刀動力刀塔, 不含刀座
- 手動中心架55~160mm
- 油壓中心架12~152mm
- 手動刀量測臂
- CS軸
- CE規範
- 變壓器

Optional equipment & accessories

- 15" hollow 3-jaw hydraulic chuck for CL-320B
- OD tool holder
- V12 Driven tool system, not including tool holder
- Manual Steady rest 55~160mm
- Self-centering steady rest 12~152mm
- Manual tool measurement arm
- CS axis function
- CE approval specification
- Transformer

□配備及附件以報價單為準 / Detail equipment & accessories based on the quotation.

**KINWA**  
金和車床

金竑精密股份有限公司

地址：台中市大雅區田心街10號  
TEL：886-4-25666113 · 25663114  
http://www.kinwa-lathe.com

CHIN HUNG MACHINERY CO., LTD.

NO. 10, TIEN SHIN STREET,  
TA-YA, TAICHUNG, TAIWAN  
E-mail: ufkinwa@ms15.hinet.net

**KINWA**  
金和車床

金和CNC車床  
KINWA CNC LATHE



CL320 x 1100

**CL-320**

夾頭 Chuck 12", 15"

旋徑 Swing 550 mm

兩心間距 Between Center 730, 1230, 2210 mm

棒材容量 Bar capacity 90, 115 mm

主軸馬達 Spindle motor 30HP

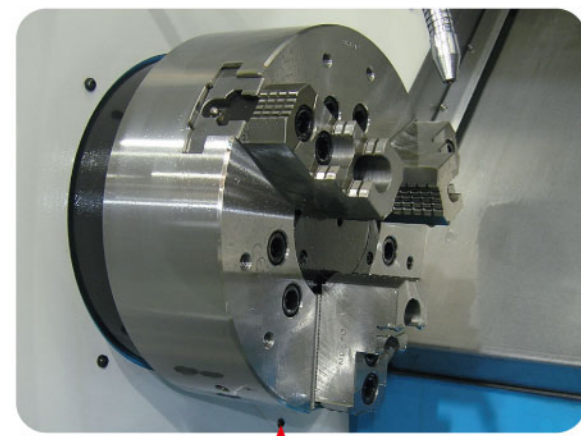

### 夾頭Chuck

- 搭配12吋中空油壓三爪夾頭，棒材容量90 mm
- CL-320B x 2000可選購15吋中空油壓三爪夾頭，棒材容量115 mm
- With 12 inch hollow 3-jaw hydraulic chuck, bar capacity 90 mm
- CL-320B x 2000 can choose 15 inch hollow 3-jaw hydraulic chuck as option, bar capacity 115 mm

### 刀塔Turret

- 立式V10油壓刀塔
- Vertical 10-station turret

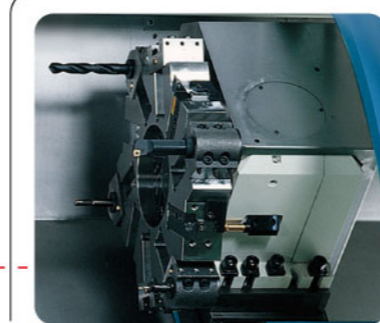

- 義製V12動力刀塔(選購)
- V12 Driven tool system made in Italy (optional)

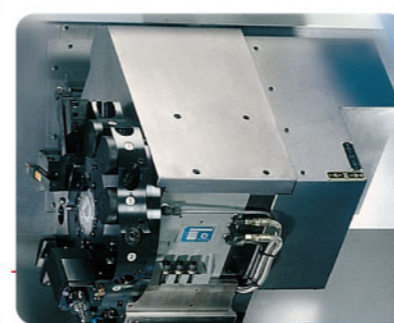

### 刀具系統 Tooling System (mm)

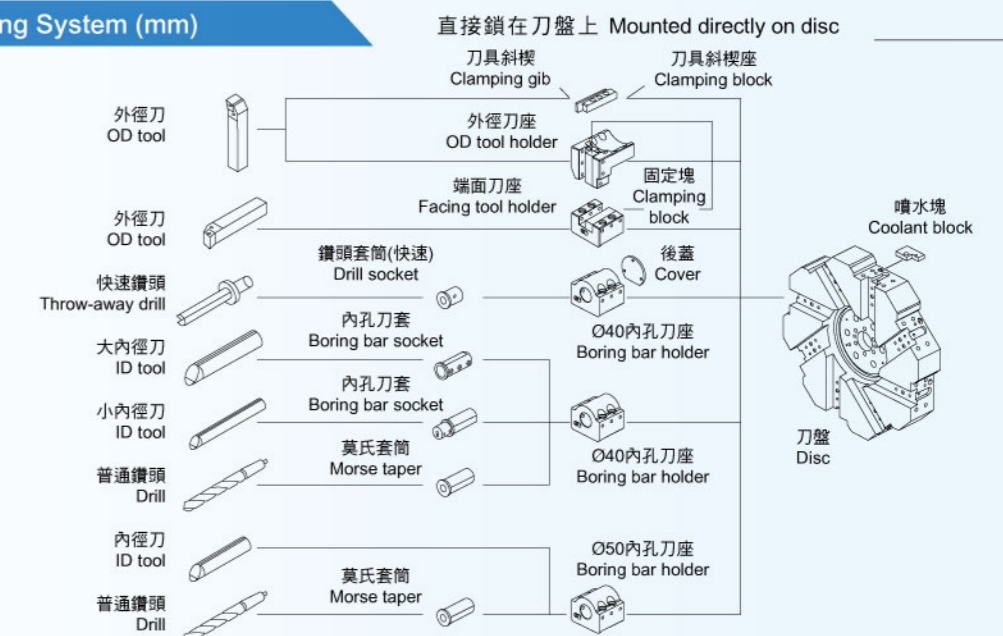

### 加工行程圖 Working Range (mm)

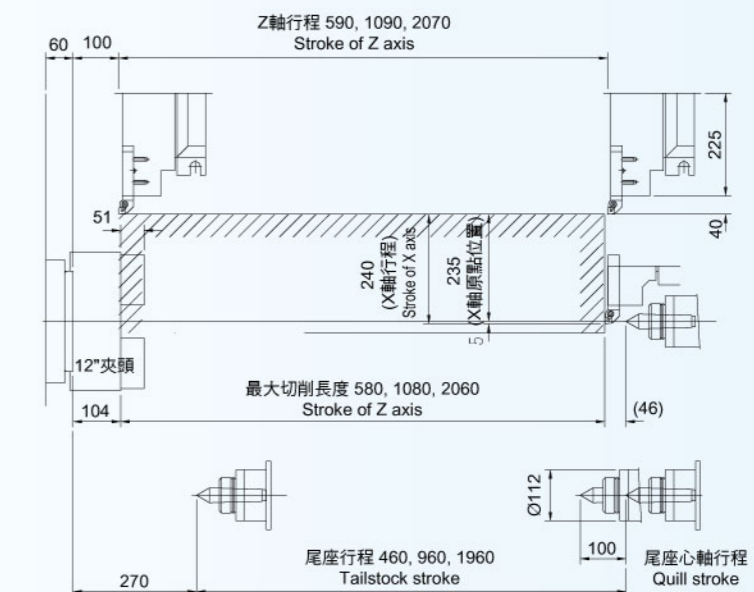

### 床身及硬軌Bed & Box way

- 45度斜床式床身
- 硬軌結構耐重切削
- 45 degree slant bed
- Box way structure for heavy duty cutting

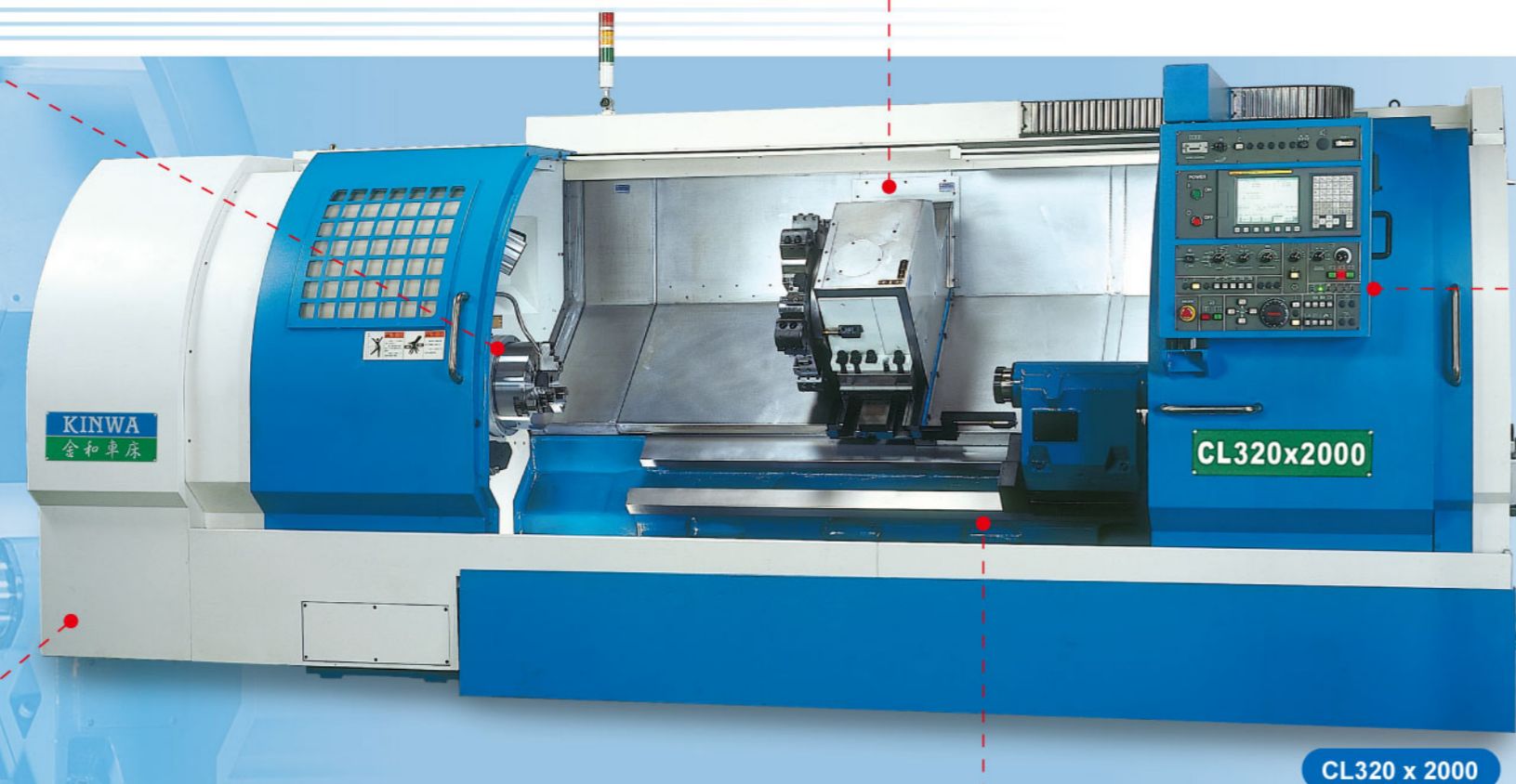

### 控制器及操作面板 Controller & Panel

- 使用FANUC電腦0iTD彩色10.4吋液晶螢幕，搭配新式操作面板
- With FANUC controller 0iTD, 10.4" color LCD and new type control panel.



### 主軸馬達Spindle motor

CL-320 搭配 30HP 主軸馬達  
CL-320 with 30HP spindle motor

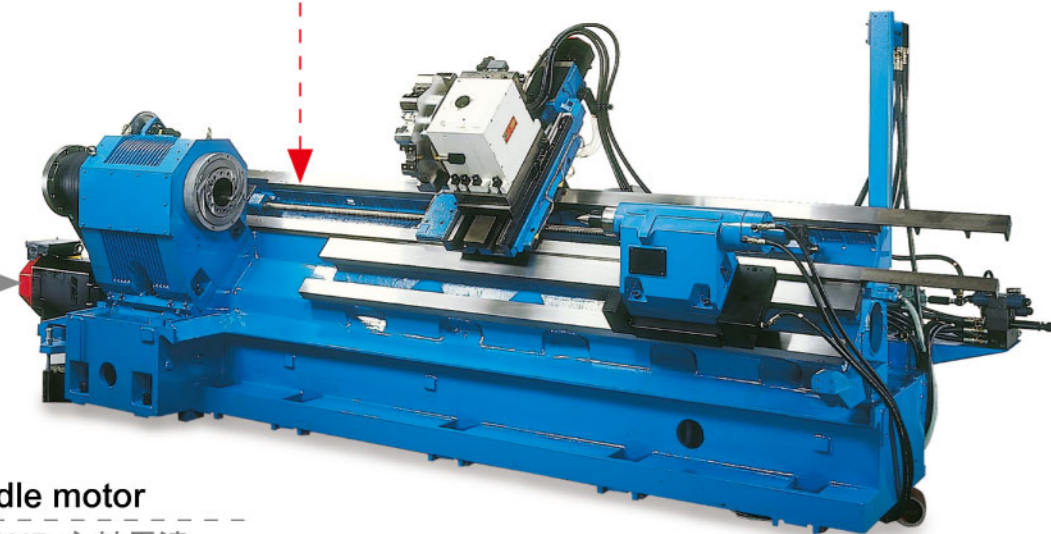

CL320 x 2000機體結構Structure

### 尾座Tailstock

- 可程式副主軸式尾座及油壓心軸，搭配固定頂針MT#4
- Programmable tailstock with built-in center, hydraulic quill and dead center MT#4

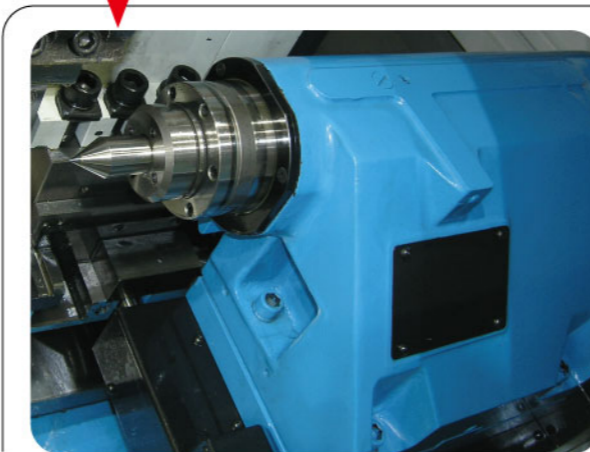

### CL320 刀具干涉圖 Tool interference (mm)

#### V10

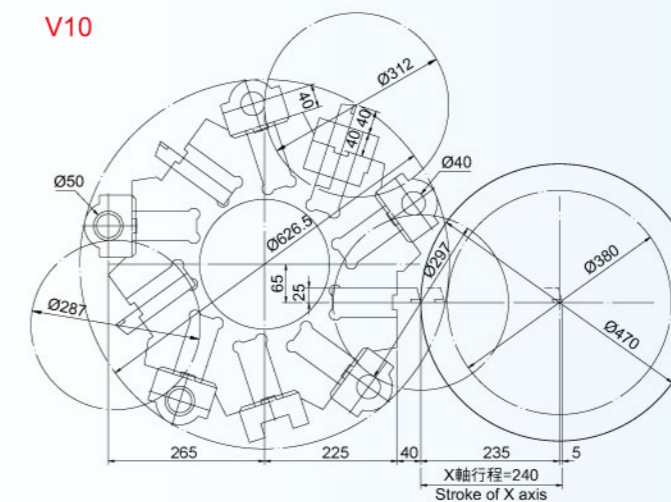

#### V12 動力刀塔 Driven tool system

